



To Val Sylaj
Canadian Precast / Prestressed
Concrete Institute
PO Box 24058 Hazeldean Road
Ottawa ON K2M 2C3

Test Date: Nov-Dec, 2021
Report Date: May 10, 2022
RDH Building Science Laboratories
167 Lexington Court #6
Waterloo ON N2J 4R9

Contents

1	General	1
2	Test Program Summary	1
2.1	Objective	1
2.2	Test Specifications	1
2.3	Test Specimen Description	1
2.4	Drawings of Specimens	5
2.5	Location of Air Seals	7
2.6	Test Parameters	9
2.7	Compliance Statement	10
3	Test Results	11
3.1	Wall 1 – Single Wythe Precast – Opaque Wall	11
3.2	Wall 2 – Single Wythe Precast – Penetrated Wall	15
3.3	Wall 3 – Double Wythe Insulated Precast – Opaque Wall	19
3.4	Wall 4 – Double Wythe Insulated Precast – Penetrated Wall	23
4	Closing	27
	Appendix A	28

1 General

Report Issued to:

Canadian Precast / Prestressed
Concrete Institute
PO Box 24058 Hazeldean Road
Ottawa ON K2M 2C3
Attn: Val Sylaj

Test Laboratory:

RDH Building Science Laboratories
167 Lexington Court #6
Waterloo ON N2J 4R9
Attn: Jonathan Smegal

Dates of Testing:

November 17, 2021 through
December 14, 2021

Date of Report:

May 10, 2022

2 Test Program Summary

2.1 Objective

This test program was established to assess the airtightness of two different precast concrete panel systems: a single wythe precast system (without insulation), and a double wythe insulated precast concrete panel system. Both systems were considered with and without intentional realistic penetrations as would be constructed in-service; this resulted in a total of four test specimens.

2.2 Test Specifications

ASTM E 2357-11, *Standard Test Method for Determining Air Leakage of Air Barrier Assemblies*.

A series of laboratory tests were performed to determine air leakage resistance, wind load performance, and durability of air barrier system. The mock-up test wall specimens were subjected to air leakage and structural performance testing using ASTM E2357. The durability of the air barrier systems was evaluated through sustained, cyclical, and gust loadings then re-tested to assess any change in air leakage performance.

2.3 Test Specimen Description

Four test specimens or “Mock-ups” were prepared for this test program. Each measured 2400 mm (94.5 in.) wide by 2400 mm (94.5 in.) high, from the exterior edges of the concrete, for a total area of 5.76 m² (62 sq.ft.). This area was exclusive of the perimeter sealed joint between the precast and test frame. Each test specimen was constructed to have a single 2400 mm (94.5 in. long horizontal joint and two 1200 mm (47.25 in.) vertical joints. The four mock-up walls were:

- Wall 1: Single wythe precast, opaque – A single, 102 mm (4 in.) thick concrete wythe; without any insulation or penetrations. Cross section at joint shown in Figure 2.7. Elevation shown in Figure 2.10.

- Wall 2: Single wythe, w/ penetrations – A single, 102 mm (4 in.) thick concrete wythe; without any insulation but with penetrations (1 window, 1 duct, 1 pipe, 2 electrical boxes). Cross section at joint shown in Figure 2.7. Elevation shown in Figure 2.11.
- Wall 3: Double wythe insulated – A 64 mm (2.5 in.) thick exterior concrete wythe; with a 76 mm (3 in.) thick layer of XPS insulation (installed continuous edge-to-edge); with a 76 mm (3 in.) thick interior concrete wythe; without any penetrations. Cross section at joint shown in Figure 2.8. Elevation shown in Figure 2.10.
- Wall 4: Double wythe insulated – A 64 mm (2.5 in.) thick exterior concrete wythe; with a 76 mm (3 in.) thick layer of XPS insulation (installed continuous edge-to-edge); with a 76 mm (3 in.) thick interior concrete wythe; with penetrations (1 window, 1 duct, 1 pipe, 2 electrical boxes). Cross section at joint shown in Figure 2.8. Elevation shown in Figure 2.11.

Precast concrete panels for the four mock-ups were fabricated by Stubbe's Precast in their plant at 44 Muir Line, Harley Ontario, N0E 1E0. Stubbe's staff mounted the precast panels on frames of hot-rolled steel angle then delivered to RDH's laboratory facility at 167 Lexington Crt., Waterloo Ontario, N2J 4R9.

The mock-ups were "seasoned" at laboratory conditions (18-24°C and 30-60% RH) for three months. RDH staff installed air and water-tight perimeter frames around the test specimens to facilitate interface, connection, and air sealing to RDH's air and water testing rig. Stubbe's staff attended the laboratory to complete installation of 2-stage sealant joints in the field of the mock-ups and 1-stage sealant joints between the mock-up and RDH's perimeter frame (See Figure 2.11 for details).



Figure 2.1 – Mock-up Wall 1, viewed from the indoor side, showing back of precast concrete panels and connections to steel frame.



Figure 2.2 - Mock-up Wall 2, viewed from the outdoor side, showing surrogate window installed in rough-opening.



Figure 2.3 - Mock-up Wall 2, viewed from the outdoor side, showing top left concrete panel and the perimeter frame. Here one of Stubbe's staff is installing backer rod in the void between the concrete panel and the penetrating metal duct.

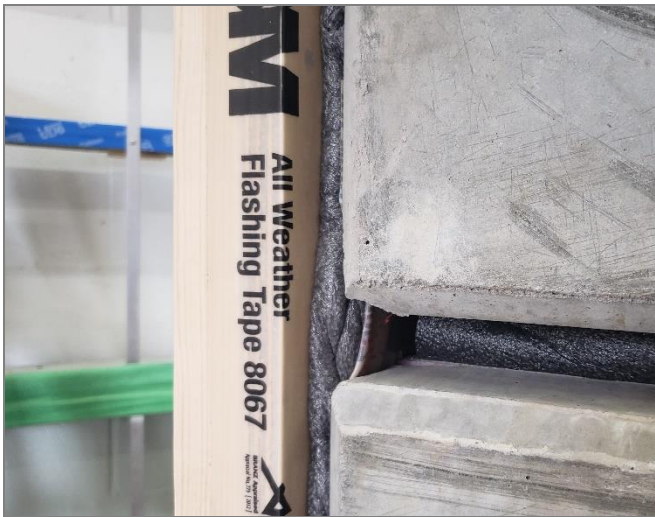

Figure 2.4 - Mock-up Wall 4, viewed from the outdoor side, showing backer-rod installed in the horizontal and perimeter joints at the left end of the test wall specimen.

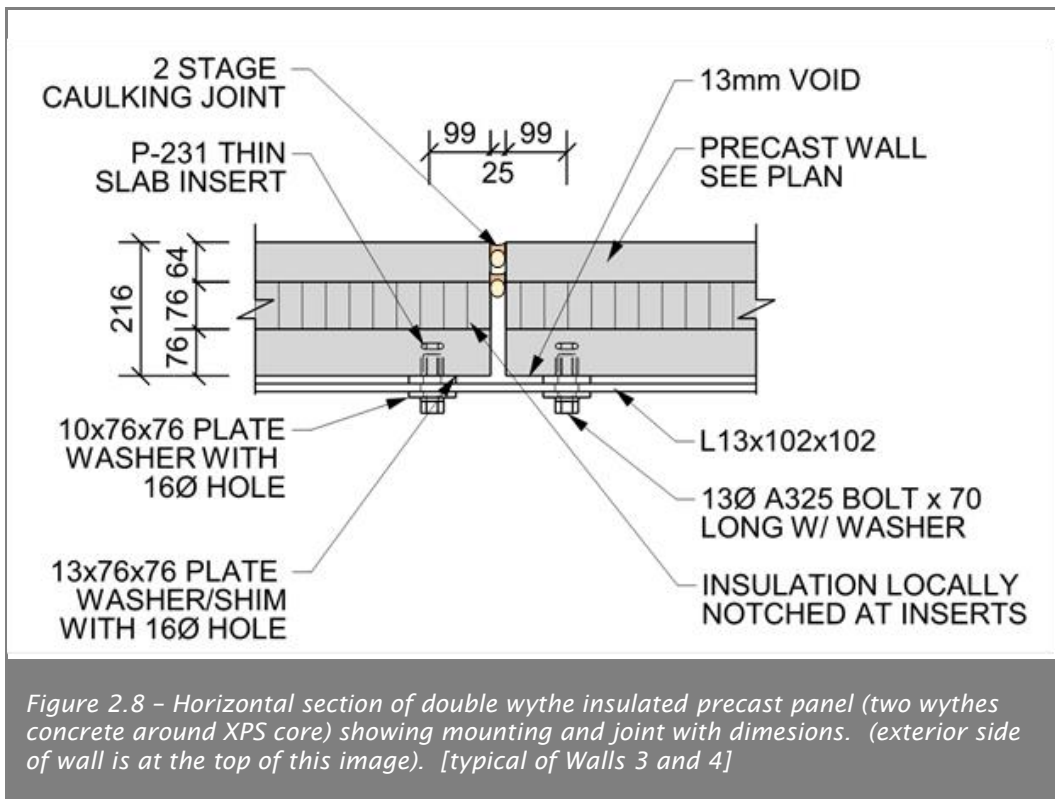
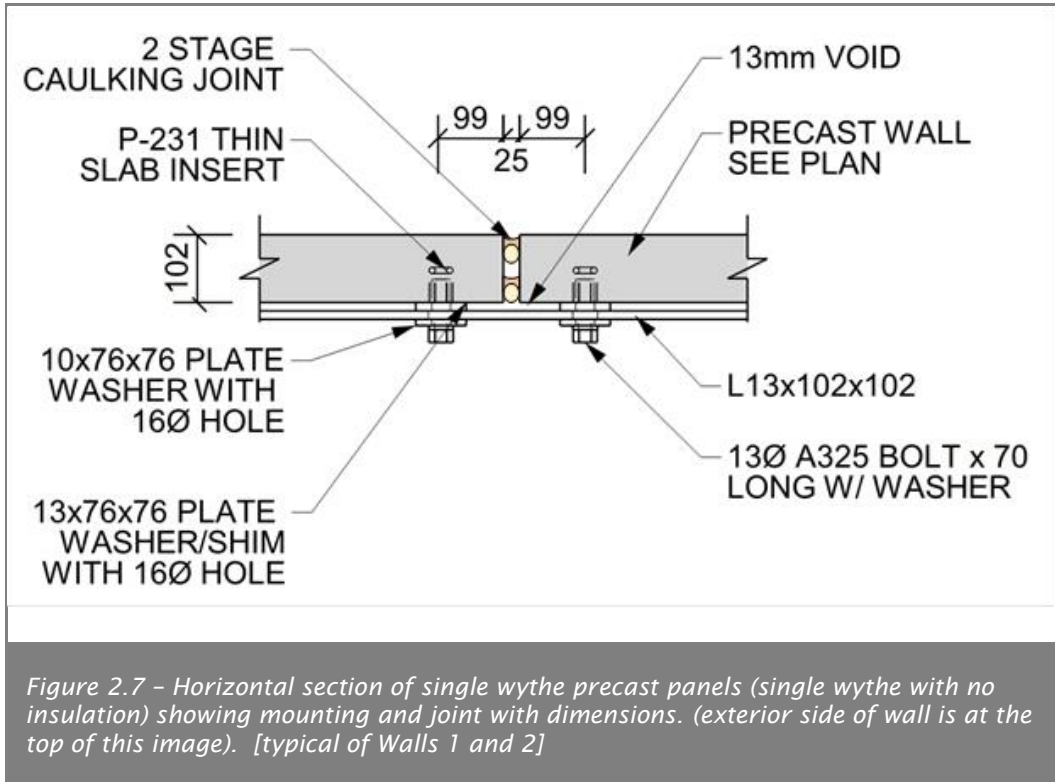

Figure 2.5 - Mock-up Wall 4, viewed from the outdoor side. Here a Stubbe's staff person is seen installing the outer seal on the 2-stage joint between the concrete panels.



Figure 2.6 - Mock-up Wall 3 completed with perimeter frame and seals, ready for testing.

2.4 Drawings of Specimens



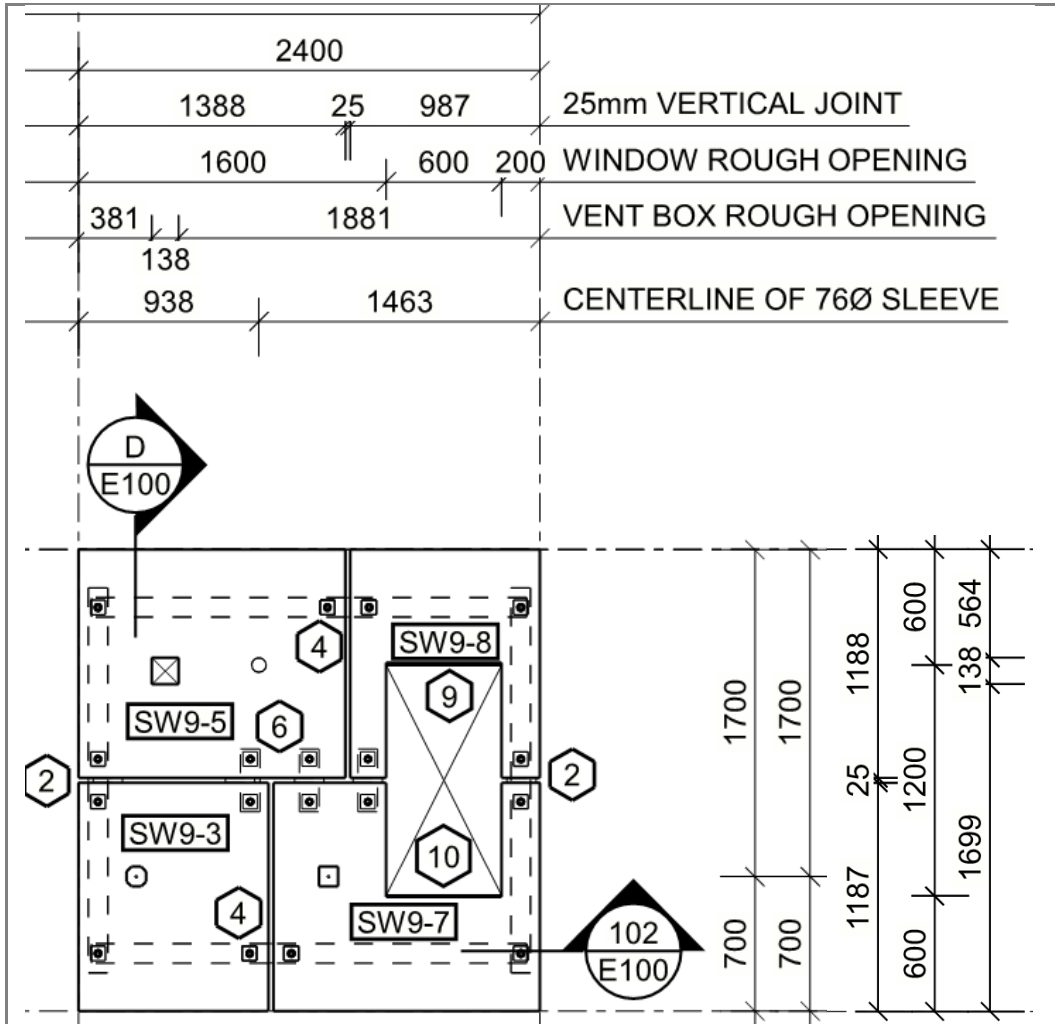
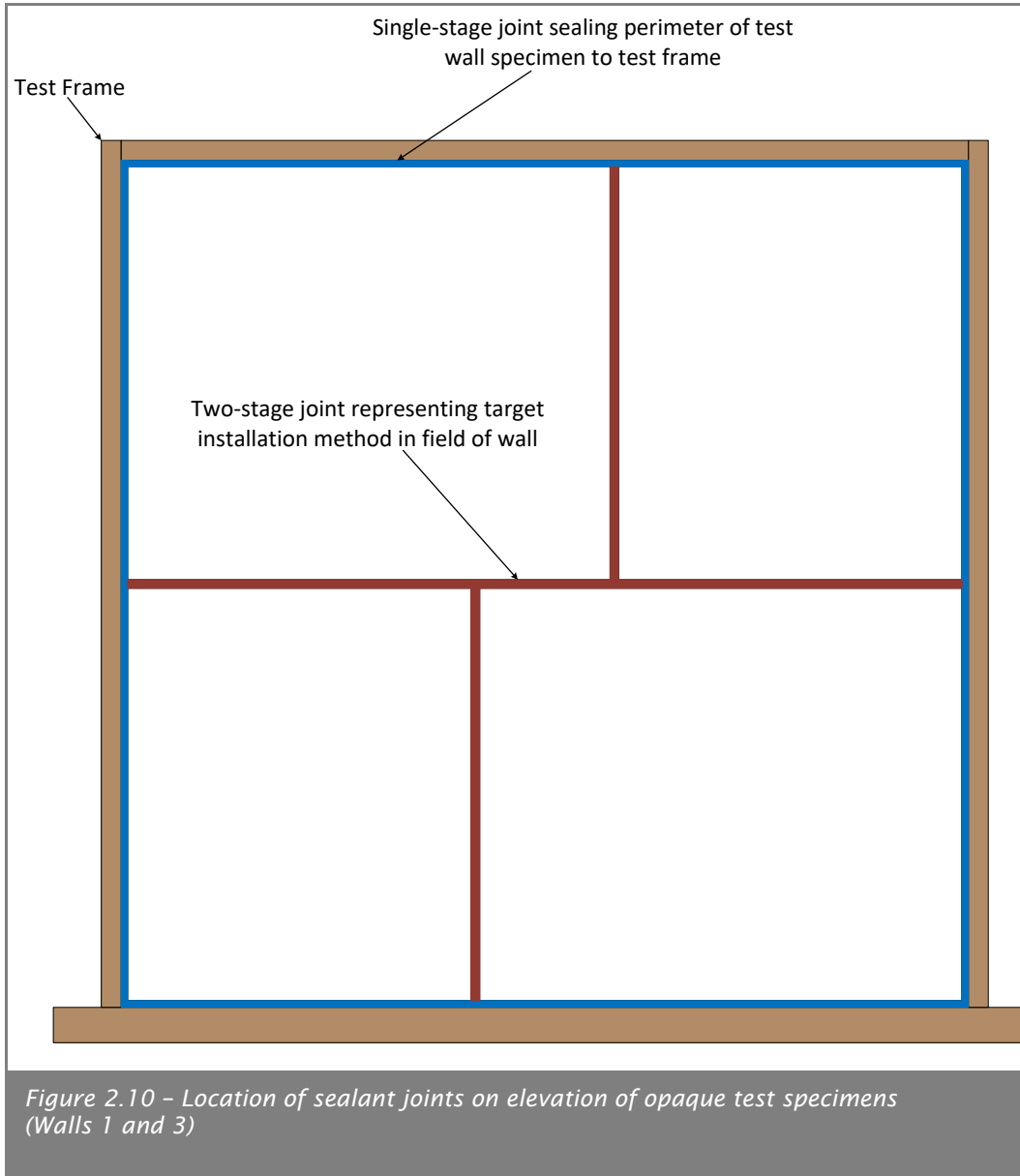

Figure 2.9 – Elevation showing panel layout and dimensions for test wall specimens (“mock-ups”) having penetrations (Walls 2 and 4). Opaque (non-penetrated) wall dimensions and panel joint layout are similar (Walls 1 and 3).

2.5 Location of Air Seals



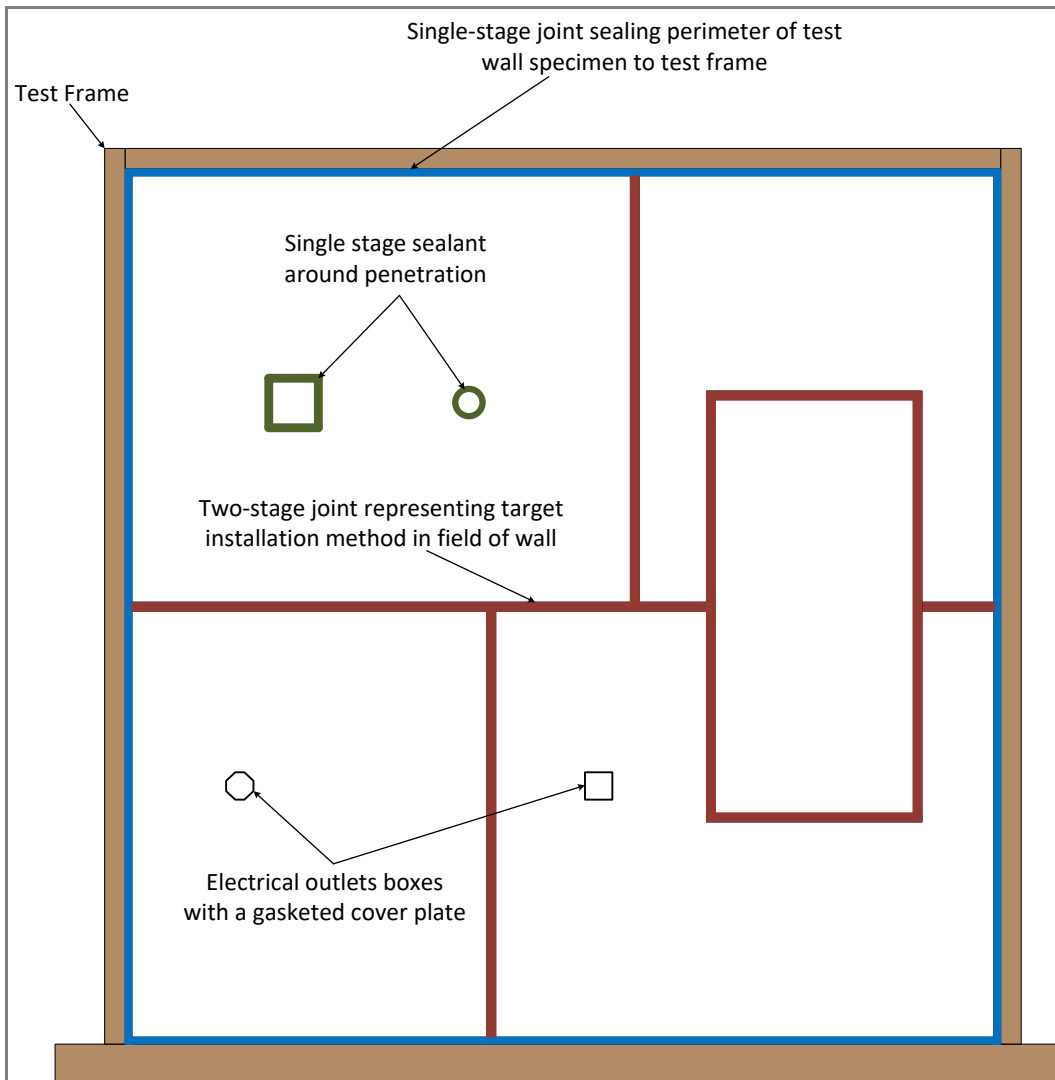
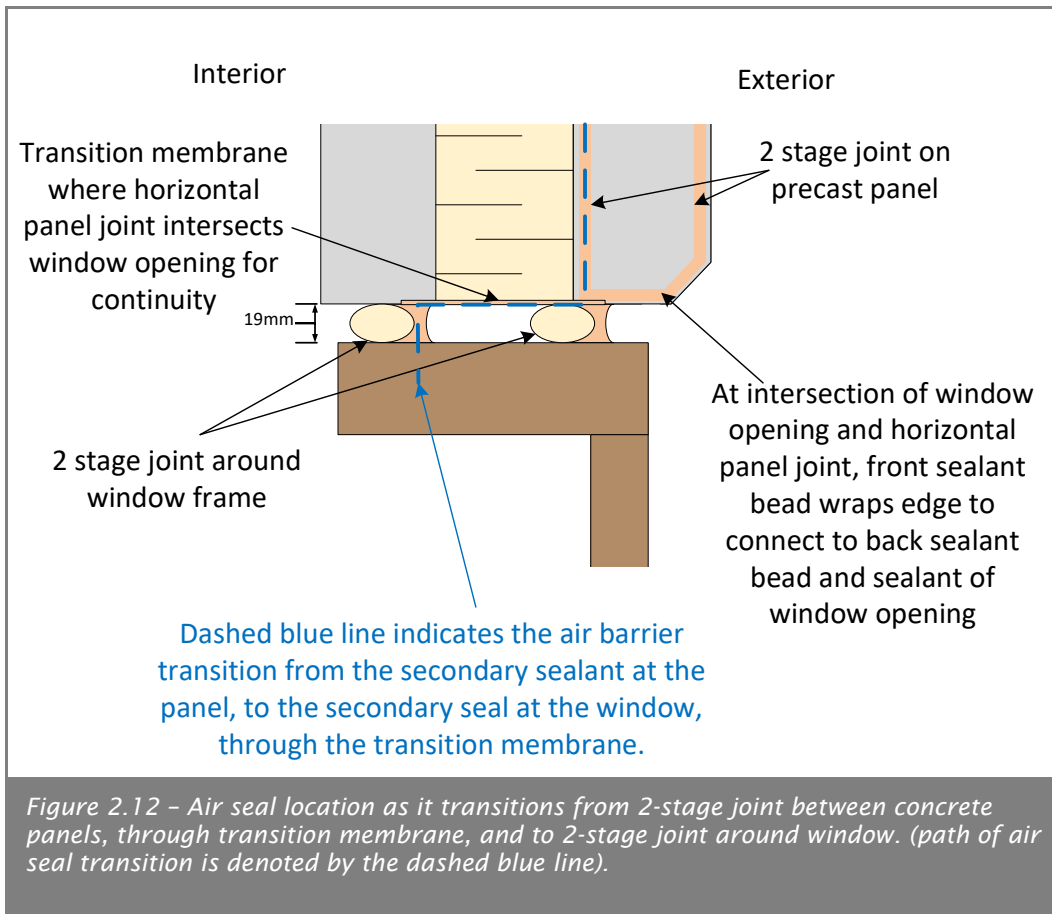

Figure 2.11 - Location of sealant joints on elevation of penetrated test specimens (Walls 2 and 4)



2.6 Test Parameters

Each of the four test specimens were subjected to the same series of tests:

- Baseline Air Leakage – Measure the assembly air leakage using a multi-point approach (e.g., at positive air pressure differentials of 25 Pa, 50 Pa, 75 Pa, 100 Pa, 250 Pa and 300 Pa; repeat with negative air pressure differentials) to determine the air leakage prior to wind pressure conditioning. Note that this same air leakage test is repeated following each applied wind pressure loading.
- Pressure Conditioning Sequence A – Sustained Loading – Apply a positive pressure differential of 600 Pa for a period of 1 hr (P1 in Figure 2.13); then apply a negative pressure differential of 600 Pa for a period of 1 hr (P'1 in Figure 2.13). Inspect for and note any visible damage then repeat positive and negative assembly air leakage test.
- Pressure Conditioning Sequence B – Cyclical Loading – Apply 1000 cycles positive pressure to 800 Pa (P2 in Figure 2.13); then repeat applying 1000 cycles negative pressure to -800 Pa (P'2 in Figure 2.13). Inspect for and note any visible damage then repeat positive and negative assembly air leakage test.
- Pressure Conditioning Sequence C – Gust Loading – Apply 1 cycle positive pressure to 1200 Pa (P3 in Figure 2.13); then repeat applying 1 cycle negative

3 Test Results

3.1 Wall 1 – Single Wythe Precast – Opaque Wall

Air Infiltration [before conditioning (loading) sequences]

Test Pressure	Total Leakage	Tare	Specimen Leakage	Leakage Rate	
Pa	lps	lps	lps	cfm/ft2	lps/m2
25	0.133	0.000	0.133	0.004	0.022
50	0.213	0.000	0.213	0.007	0.036
75	0.278	0.000	0.278	0.009	0.047
100	0.347	0.000	0.347	0.011	0.058
150	0.480	0.000	0.480	0.016	0.081
250	0.666	0.000	0.666	0.022	0.112
300	0.727	0.000	0.727	0.024	0.122

Air Exfiltration [before conditioning (loading) sequences]

Test Pressure	Total Leakage	Tare	Specimen Leakage	Leakage Rate	
Pa	lps	lps	lps	cfm/ft2	lps/m2
25	0.137	0.000	0.137	0.005	0.023
50	0.210	0.000	0.210	0.007	0.035
75	0.270	0.000	0.270	0.009	0.045
100	0.338	0.000	0.338	0.011	0.057
150	0.459	0.000	0.459	0.015	0.077
250	0.631	0.000	0.631	0.021	0.106
300	0.707	0.000	0.707	0.023	0.119

Pressure Conditioning (loading) Sequence A

Title of Test	Pressure	Duration	Test Results
-	Pa	min	-
Sustained +ve	+600	60	No damage noted
Sustained -ve	-600	60	No damage noted

3.1 Wall 1 – Single Wythe Precast – Opaque Wall (Continued)

Air Infiltration [after conditioning (loading) sequence A]

Test Pressure	Total Leakage	Tare	Specimen Leakage	Leakage Rate	
				cfm/ft2	lps/m2
Pa	lps	lps	lps		
25	0.153	0.000	0.153	0.005	0.026
50	0.239	0.000	0.239	0.008	0.040
75	0.309	0.000	0.309	0.010	0.052
100	0.386	0.000	0.386	0.013	0.065
150	0.533	0.000	0.533	0.018	0.090
250	0.713	0.000	0.713	0.024	0.120
300	0.807	0.000	0.807	0.027	0.136

Air Exfiltration [after conditioning (loading) sequence A]

Test Pressure	Total Leakage	Tare	Specimen Leakage	Leakage Rate	
				cfm/ft2	lps/m2
Pa	lps	lps	lps		
25	0.141	0.000	0.141	0.005	0.024
50	0.219	0.000	0.219	0.007	0.037
75	0.282	0.000	0.282	0.009	0.047
100	0.350	0.000	0.350	0.012	0.059
150	0.476	0.000	0.476	0.016	0.080
250	0.646	0.000	0.646	0.021	0.109
300	0.729	0.000	0.729	0.024	0.123

Pressure Conditioning (loading) Sequence B

Title of Test	Pressure	Cycles	Test Results
-	Pa	Count	-
Cyclic Load +ve	+800	1000	No damage noted
Cyclic Load -ve	-800	1000	No damage noted

3.1 Wall 1 – Single Wythe Precast – Opaque Wall (Continued)

Air Infiltration [after conditioning (loading) sequence B]

Test Pressure	Total Leakage	Tare	Specimen Leakage	Leakage Rate	
				cfm/ft2	lps/m2
Pa	lps	lps	lps		
25	0.047	0.000	0.047	0.002	0.008
50	0.076	0.000	0.076	0.003	0.013
75	0.102	0.000	0.102	0.003	0.017
100	0.129	0.000	0.129	0.004	0.022
150	0.172	0.000	0.172	0.006	0.029
250	0.272	0.000	0.272	0.009	0.046
300	0.309	0.000	0.309	0.010	0.052

Air Exfiltration [after conditioning (loading) sequence B]

Test Pressure	Total Leakage	Tare	Specimen Leakage	Leakage Rate	
				cfm/ft2	lps/m2
Pa	lps	lps	lps		
25	0.039	0.000	0.039	0.001	0.007
50	0.058	0.000	0.058	0.002	0.010
75	0.075	0.000	0.075	0.002	0.013
100	0.091	0.000	0.091	0.003	0.015
150	0.121	0.000	0.121	0.004	0.020
250	0.165	0.000	0.164	0.005	0.028
300	0.186	0.000	0.186	0.006	0.031

Pressure Conditioning (loading) Sequence C

Title of Test	Pressure	Cycles	Test Results
-	Pa	Count	-
Gust Load +ve	+1200	1	No damage noted
Gust Load -ve	-1200	1	No damage noted; Suspect cycling caused a joint to seat, eliminating a leakage path

3.1 Wall 1 – Single Wythe Precast – Opaque Wall (Continued)

Air Infiltration [after conditioning (loading) sequence C]

Test Pressure	Total Leakage	Tare	Specimen Leakage	Leakage Rate	
				cfm/ft2	lps/m2
Pa	lps	lps	lps	cfm/ft2	lps/m2
25	0.045	0.000	0.045	0.001	0.008
50	0.071	0.000	0.071	0.002	0.012
75	0.093	0.000	0.093	0.003	0.016
100	0.118	0.000	0.118	0.004	0.020
150	0.157	0.000	0.157	0.005	0.026
250	0.235	0.000	0.235	0.008	0.040
300	0.274	0.000	0.274	0.009	0.046

Air Exfiltration [after conditioning (loading) sequence C]

Test Pressure	Total Leakage	Tare	Specimen Leakage	Leakage Rate	
				cfm/ft2	lps/m2
Pa	lps	lps	lps	cfm/ft2	lps/m2
25	0.049	0.000	0.049	0.002	0.008
50	0.077	0.000	0.077	0.003	0.013
75	0.102	0.000	0.102	0.003	0.017
100	0.124	0.000	0.124	0.004	0.021
150	0.161	0.000	0.161	0.005	0.027
250	0.239	0.000	0.239	0.008	0.040
300	0.274	0.000	0.274	0.009	0.046

3.2 Wall 2 – Single Wythe Precast – Penetrated Wall

Air Infiltration [before conditioning (loading) sequences]

Test Pressure	Total Leakage	Tare	Specimen Leakage	Leakage Rate	
Pa	lps	lps	lps	cfm/ft2	lps/m2
25	0.094	0.000	0.094	0.003	0.016
50	0.156	0.000	0.156	0.005	0.026
75	0.212	0.000	0.212	0.007	0.036
100	0.272	0.000	0.272	0.009	0.046
150	0.382	0.000	0.382	0.013	0.064
250	0.580	0.000	0.580	0.019	0.098
300	0.654	0.000	0.654	0.022	0.110

Air Exfiltration [before conditioning (loading) sequences]

Test Pressure	Total Leakage	Tare	Specimen Leakage	Leakage Rate	
Pa	lps	lps	lps	cfm/ft2	lps/m2
25	0.098	0.000	0.098	0.003	0.016
50	0.159	0.000	0.159	0.005	0.027
75	0.212	0.000	0.212	0.007	0.036
100	0.268	0.000	0.268	0.009	0.045
150	0.378	0.000	0.378	0.013	0.064
250	0.533	0.000	0.533	0.018	0.090
300	0.611	0.000	0.611	0.020	0.103

Pressure Conditioning (loading) Sequence A

Title of Test	Pressure	Duration	Test Results
-	Pa	min	-
Sustained +ve	+600	60	No damage noted
Sustained -ve	-600	60	No damage noted

3.2 Wall 2 – Single Wythe Precast – Penetrated Wall (Continued)

Air Infiltration [after conditioning (loading) sequence A]

Test Pressure	Total Leakage	Tare	Specimen Leakage	Leakage Rate	
				cfm/ft2	lps/m2
Pa	lps	lps	lps		
25	0.090	0.000	0.090	0.003	0.015
50	0.155	0.000	0.155	0.005	0.026
75	0.212	0.000	0.212	0.007	0.036
100	0.273	0.000	0.273	0.009	0.046
150	0.392	0.000	0.392	0.013	0.066
250	0.572	0.000	0.572	0.019	0.096
300	0.658	0.000	0.658	0.022	0.111

Air Exfiltration [after conditioning (loading) sequence A]

Test Pressure	Total Leakage	Tare	Specimen Leakage	Leakage Rate	
				cfm/ft2	lps/m2
Pa	lps	lps	lps		
25	0.094	0.000	0.094	0.003	0.016
50	0.154	0.000	0.154	0.005	0.026
75	0.208	0.000	0.208	0.007	0.035
100	0.265	0.000	0.265	0.009	0.045
150	0.360	0.000	0.360	0.012	0.061
250	0.560	0.000	0.560	0.019	0.094
300	0.643	0.000	0.642	0.021	0.108

Pressure Conditioning (loading) Sequence B

Title of Test	Pressure	Cycles	Test Results
-	Pa	Count	-
Cyclic Load +ve	+800	1000	No damage noted
Cyclic Load -ve	-800	1000	No damage noted

3.2 Wall 2 – Single Wythe Precast – Penetrated Wall (Continued)

Air Infiltration [after conditioning (loading) sequence B]

Test Pressure	Total Leakage	Tare	Specimen Leakage	Leakage Rate	
				cfm/ft2	lps/m2
Pa	lps	lps	lps		
25	0.080	0.000	0.080	0.003	0.014
50	0.136	0.000	0.136	0.004	0.023
75	0.185	0.000	0.185	0.006	0.031
100	0.237	0.000	0.237	0.008	0.040
150	0.331	0.000	0.331	0.011	0.056
250	0.501	0.000	0.501	0.017	0.084
300	0.578	0.000	0.578	0.019	0.097

Air Exfiltration [after conditioning (loading) sequence B]

Test Pressure	Total Leakage	Tare	Specimen Leakage	Leakage Rate	
				cfm/ft2	lps/m2
Pa	lps	lps	lps		
25	0.086	0.000	0.086	0.003	0.014
50	0.140	0.000	0.140	0.005	0.023
75	0.188	0.000	0.188	0.006	0.032
100	0.239	0.000	0.239	0.008	0.040
150	0.325	0.000	0.325	0.011	0.055
250	0.498	0.000	0.497	0.016	0.084
300	0.572	0.000	0.572	0.019	0.096

Pressure Conditioning (loading) Sequence C

Title of Test	Pressure	Cycles	Test Results
-	Pa	Count	-
Gust Load +ve	+1200	1	No damage noted
Gust Load -ve	-1200	1	No damage noted

3.2 Wall 2 – Single Wythe Precast – Penetrated Wall (Continued)

Air Infiltration [after conditioning (loading) sequence C]

Test Pressure	Total Leakage	Tare	Specimen Leakage	Leakage Rate	
				cfm/ft2	lps/m2
Pa	lps	lps	lps		
25	0.086	0.000	0.086	0.003	0.014
50	0.142	0.000	0.142	0.005	0.024
75	0.194	0.000	0.194	0.006	0.033
100	0.247	0.000	0.247	0.008	0.042
150	0.345	0.000	0.345	0.011	0.058
250	0.517	0.000	0.517	0.017	0.087
300	0.595	0.000	0.595	0.020	0.100

Air Exfiltration [after conditioning (loading) sequence C]

Test Pressure	Total Leakage	Tare	Specimen Leakage	Leakage Rate	
				cfm/ft2	lps/m2
Pa	lps	lps	lps		
25	0.090	0.000	0.090	0.003	0.015
50	0.147	0.000	0.147	0.005	0.025
75	0.196	0.000	0.196	0.006	0.033
100	0.251	0.000	0.251	0.008	0.042
150	0.345	0.000	0.345	0.011	0.058
250	0.517	0.000	0.517	0.017	0.087
300	0.599	0.000	0.599	0.020	0.101

3.3 Wall 3 – Double Wythe Insulated Precast – Opaque Wall

Air Infiltration [before conditioning (loading) sequences]

Test Pressure	Total Leakage	Tare	Specimen Leakage	Leakage Rate	
Pa	lps	lps	lps	cfm/ft2	lps/m2
25	0.059	0.000	0.059	0.002	0.010
50	0.089	0.000	0.089	0.003	0.015
75	0.114	0.000	0.114	0.004	0.019
100	0.139	0.000	0.139	0.005	0.023
150	0.180	0.000	0.180	0.006	0.030
250	0.255	0.000	0.255	0.008	0.043
300	0.290	0.000	0.290	0.010	0.049

Air Exfiltration [before conditioning (loading) sequences]

Test Pressure	Total Leakage	Tare	Specimen Leakage	Leakage Rate	
Pa	lps	lps	lps	cfm/ft2	lps/m2
25	0.065	0.000	0.065	0.002	0.011
50	0.095	0.000	0.095	0.003	0.016
75	0.121	0.000	0.121	0.004	0.020
100	0.146	0.000	0.146	0.005	0.025
150	0.182	0.000	0.182	0.006	0.031
250	0.270	0.000	0.270	0.009	0.045
300	0.294	0.000	0.294	0.010	0.049

Pressure Conditioning (loading) Sequence A

Title of Test	Pressure	Duration	Test Results
-	Pa	min	-
Sustained +ve	+600	60	No damage noted
Sustained -ve	-600	60	No damage noted

3.3 Wall 3 – Double Wythe Insulated Precast – Opaque Wall

(Continued)

Air Infiltration [after conditioning (loading) sequence A]

Test Pressure	Total Leakage	Tare	Specimen Leakage	Leakage Rate	
				cfm/ft2	lps/m2
Pa	lps	lps	lps	cfm/ft2	lps/m2
25	0.063	0.000	0.063	0.002	0.011
50	0.093	0.000	0.093	0.003	0.016
75	0.119	0.000	0.119	0.004	0.020
100	0.143	0.000	0.143	0.005	0.024
150	0.180	0.000	0.180	0.006	0.030
250	0.259	0.000	0.258	0.009	0.043
300	0.294	0.000	0.294	0.010	0.049

Air Exfiltration [after conditioning (loading) sequence A]

Test Pressure	Total Leakage	Tare	Specimen Leakage	Leakage Rate	
				cfm/ft2	lps/m2
Pa	lps	lps	lps	cfm/ft2	lps/m2
25	0.067	0.000	0.067	0.002	0.011
50	0.099	0.000	0.099	0.003	0.017
75	0.127	0.000	0.127	0.004	0.021
100	0.152	0.000	0.152	0.005	0.026
150	0.190	0.000	0.190	0.006	0.032
250	0.274	0.000	0.274	0.009	0.046
300	0.309	0.000	0.309	0.010	0.052

Pressure Conditioning (loading) Sequence B

Title of Test	Pressure	Cycles	Test Results
-	Pa	Count	-
Cyclic Load +ve	+800	1000	No damage noted
Cyclic Load -ve	-800	1000	No damage noted

3.3 Wall 3 – Double Wythe Insulated Precast – Opaque Wall

(Continued)

Air Infiltration [after conditioning (loading) sequence B]

Test Pressure	Total Leakage	Tare	Specimen Leakage	Leakage Rate	
				cfm/ft2	lps/m2
Pa	lps	lps	lps		
25	0.067	0.000	0.067	0.002	0.011
50	0.102	0.000	0.101	0.003	0.017
75	0.131	0.000	0.131	0.004	0.022
100	0.163	0.000	0.163	0.005	0.027
150	0.212	0.000	0.212	0.007	0.036
250	0.313	0.000	0.313	0.010	0.053
300	0.357	0.000	0.356	0.012	0.060

Air Exfiltration [after conditioning (loading) sequence B]

Test Pressure	Total Leakage	Tare	Specimen Leakage	Leakage Rate	
				cfm/ft2	lps/m2
Pa	lps	lps	lps		
25	0.069	0.000	0.069	0.002	0.012
50	0.105	0.000	0.105	0.003	0.018
75	0.139	0.000	0.139	0.005	0.023
100	0.169	0.000	0.169	0.006	0.028
150	0.216	0.000	0.216	0.007	0.036
250	0.317	0.000	0.317	0.011	0.053
300	0.364	0.000	0.364	0.012	0.061

Pressure Conditioning (loading) Sequence C

Title of Test	Pressure	Cycles	Test Results
-	Pa	Count	-
Gust Load +ve	+1200	1	No damage noted
Gust Load -ve	-1200	1	No damage noted

3.3 Wall 3 – Double Wythe Insulated Precast – Opaque Wall

(Continued)

Air Infiltration [after conditioning (loading) sequence C]

Test Pressure	Total Leakage	Tare	Specimen Leakage	Leakage Rate	
				cfm/ft2	lps/m2
Pa	lps	lps	lps		
25	0.063	0.000	0.063	0.002	0.011
50	0.096	0.000	0.096	0.003	0.016
75	0.125	0.000	0.125	0.004	0.021
100	0.156	0.000	0.155	0.005	0.026
150	0.204	0.000	0.204	0.007	0.034
250	0.298	0.000	0.298	0.010	0.050
300	0.345	0.000	0.345	0.011	0.058

Air Exfiltration [after conditioning (loading) sequence C]

Test Pressure	Total Leakage	Tare	Specimen Leakage	Leakage Rate	
				cfm/ft2	lps/m2
Pa	lps	lps	lps		
25	0.067	0.000	0.067	0.002	0.011
50	0.103	0.000	0.103	0.003	0.017
75	0.135	0.000	0.135	0.004	0.023
100	0.164	0.000	0.164	0.005	0.028
150	0.212	0.000	0.212	0.007	0.036
250	0.309	0.000	0.309	0.010	0.052
300	0.349	0.000	0.349	0.012	0.059

3.4 Wall 4 – Double Wythe Insulated Precast – Penetrated Wall

Air Infiltration [before conditioning (loading) sequences]

Test Pressure	Total Leakage	Tare	Specimen Leakage	Leakage Rate	
Pa	lps	lps	lps	cfm/ft2	lps/m2
25	0.176	0.000	0.176	0.006	0.030
50	0.298	0.000	0.298	0.010	0.050
75	0.421	0.000	0.421	0.014	0.071
100	0.489	0.000	0.489	0.016	0.082
150	0.652	0.000	0.652	0.022	0.110
250	0.925	0.000	0.924	0.031	0.155
300	1.058	0.000	1.058	0.035	0.178

Air Exfiltration [before conditioning (loading) sequences]

Test Pressure	Total Leakage	Tare	Specimen Leakage	Leakage Rate	
Pa	lps	lps	lps	cfm/ft2	lps/m2
25	0.184	0.000	0.184	0.006	0.031
50	0.299	0.000	0.299	0.010	0.050
75	0.406	0.000	0.406	0.013	0.068
100	0.487	0.000	0.487	0.016	0.082
150	0.646	0.000	0.646	0.021	0.109
250	0.921	0.000	0.921	0.030	0.155
300	1.062	0.000	1.062	0.035	0.179

Pressure Conditioning (loading) Sequence A

Title of Test	Pressure	Duration	Test Results
-	Pa	min	-
Sustained +ve	+600	60	No damage noted
Sustained -ve	-600	60	No damage noted

3.4 Wall 4 – Double Wythe Insulated Precast – Penetrated Wall (Continued)

Air Infiltration [after conditioning (loading) sequence A]

Test Pressure	Total Leakage	Tare	Specimen Leakage	Leakage Rate	
				cfm/ft2	lps/m2
Pa	lps	lps	lps	cfm/ft2	lps/m2
25	0.180	0.000	0.180	0.006	0.030
50	0.310	0.000	0.310	0.010	0.052
75	0.435	0.000	0.435	0.014	0.073
100	0.509	0.000	0.509	0.017	0.086
150	0.684	0.000	0.684	0.023	0.115
250	0.964	0.000	0.964	0.032	0.162
300	1.097	0.000	1.097	0.036	0.184

Air Exfiltration [after conditioning (loading) sequence A]

Test Pressure	Total Leakage	Tare	Specimen Leakage	Leakage Rate	
				cfm/ft2	lps/m2
Pa	lps	lps	lps	cfm/ft2	lps/m2
25	0.192	0.000	0.192	0.006	0.032
50	0.314	0.000	0.314	0.010	0.053
75	0.425	0.000	0.425	0.014	0.071
100	0.509	0.000	0.509	0.017	0.086
150	0.682	0.000	0.682	0.023	0.115
250	0.956	0.000	0.956	0.032	0.161
300	1.070	0.000	1.069	0.035	0.180

Pressure Conditioning (loading) Sequence B

Title of Test	Pressure	Cycles	Test Results
-	Pa	Count	-
Cyclic Load +ve	+800	1000	No damage noted
Cyclic Load -ve	-800	1000	No damage noted

3.4 Wall 4 – Double Wythe Insulated Precast – Penetrated Wall (Continued)

Air Infiltration [after conditioning (loading) sequence B]

Test Pressure	Total Leakage	Tare	Specimen Leakage	Leakage Rate	
				cfm/ft2	lps/m2
Pa	lps	lps	lps		
25	0.239	0.000	0.239	0.008	0.040
50	0.395	0.000	0.395	0.013	0.066
75	0.539	0.000	0.539	0.018	0.091
100	0.636	0.000	0.636	0.021	0.107
150	0.854	0.000	0.854	0.028	0.144
250	1.183	0.000	1.183	0.039	0.199
300	1.305	0.000	1.304	0.043	0.219

Air Exfiltration [after conditioning (loading) sequence B]

Test Pressure	Total Leakage	Tare	Specimen Leakage	Leakage Rate	
				cfm/ft2	lps/m2
Pa	lps	lps	lps		
25	0.223	0.000	0.223	0.007	0.038
50	0.377	0.000	0.377	0.012	0.063
75	0.521	0.000	0.521	0.017	0.088
100	0.611	0.000	0.611	0.020	0.103
150	0.827	0.000	0.827	0.027	0.139
250	1.140	0.000	1.140	0.038	0.192
300	1.261	0.000	1.261	0.042	0.212

Pressure Conditioning (loading) Sequence C

Title of Test	Pressure	Cycles	Test Results
-	Pa	Count	-
Gust Load +ve	+1200	1	No damage noted
Gust Load -ve	-1200	1	No damage noted

3.4 Wall 4 – Double Wythe Insulated Precast – Penetrated Wall (Continued)

Air Infiltration [after conditioning (loading) sequence C]

Test Pressure	Total Leakage	Tare	Specimen Leakage	Leakage Rate	
				cfm/ft2	lps/m2
Pa	lps	lps	lps	cfm/ft2	lps/m2
25	0.204	0.000	0.204	0.007	0.034
50	0.344	0.000	0.344	0.011	0.058
75	0.477	0.000	0.477	0.016	0.080
100	0.569	0.000	0.569	0.019	0.096
150	0.772	0.000	0.772	0.026	0.130
250	1.081	0.000	1.081	0.036	0.182
300	1.246	0.000	1.246	0.041	0.210

Air Exfiltration [after conditioning (loading) sequence C]

Test Pressure	Total Leakage	Tare	Specimen Leakage	Leakage Rate	
				cfm/ft2	lps/m2
Pa	lps	lps	lps	cfm/ft2	lps/m2
25	0.208	0.000	0.208	0.007	0.035
50	0.354	0.000	0.354	0.012	0.060
75	0.494	0.000	0.494	0.016	0.083
100	0.577	0.000	0.577	0.019	0.097
150	0.782	0.000	0.782	0.026	0.131
250	1.077	0.000	1.077	0.036	0.181
300	1.211	0.000	1.210	0.040	0.204

Reference Appendix A for Air Leakage Graphs and 95% confidence interval.

4 Closing

This test report does not constitute certification of the products or system under consideration. Nothing contained in this document shall represent an engineering opinion or endorsement by RDH Building Science Laboratories. The test results relate only to those products and systems tested. This report is the exclusive property of the client and shall not be reproduced, except in full, without the written approval of RDH.

Yours truly,



Chris Schumacher | M.A.Sc.
Principal, Senior Building Science Specialist
cschumacher@rdh.com
T 548-889-0067
RDH Building Science Inc.



Jonathan Smegal | M.A.Sc.
Associate, Senior Project Manager
jsmegal@rdh.com
T 548-889-0073
RDH Building Science Inc.

Reviewed by
John Straube | P.h.D., P.Eng.
Principal, Senior Building Science Specialist
jstraube@rdh.com
T 519-741-7920
RDH Building Science Inc.

Appendix A

Air Leakage Graphs



**Wall 1 – Single Wythe Precast – Opaque Wall
Baseline Infiltration**

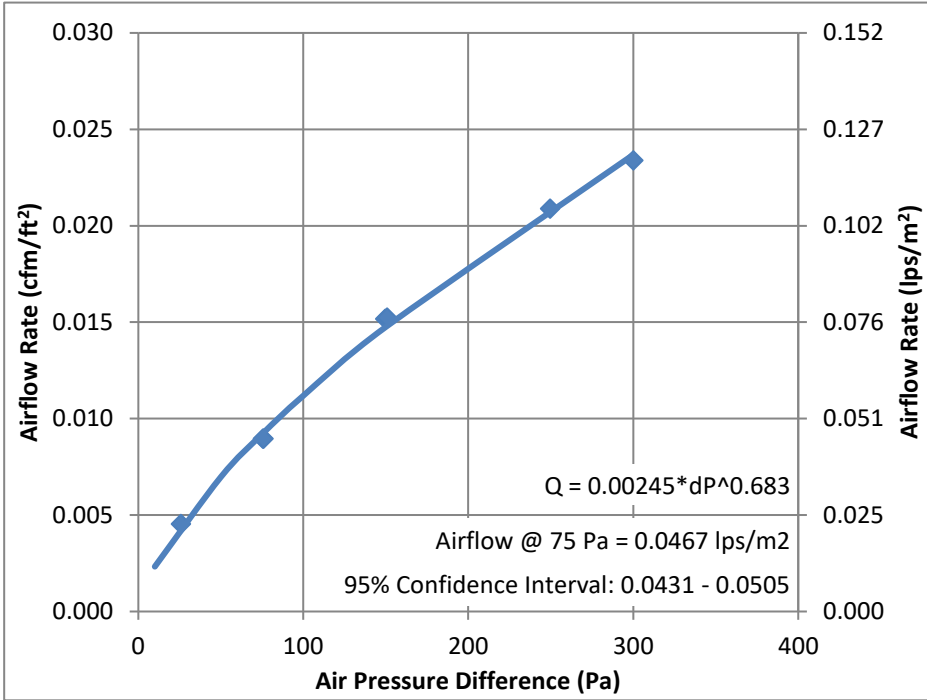

**Wall 1 – Single Wythe Precast – Opaque Wall
Baseline Exfiltration**

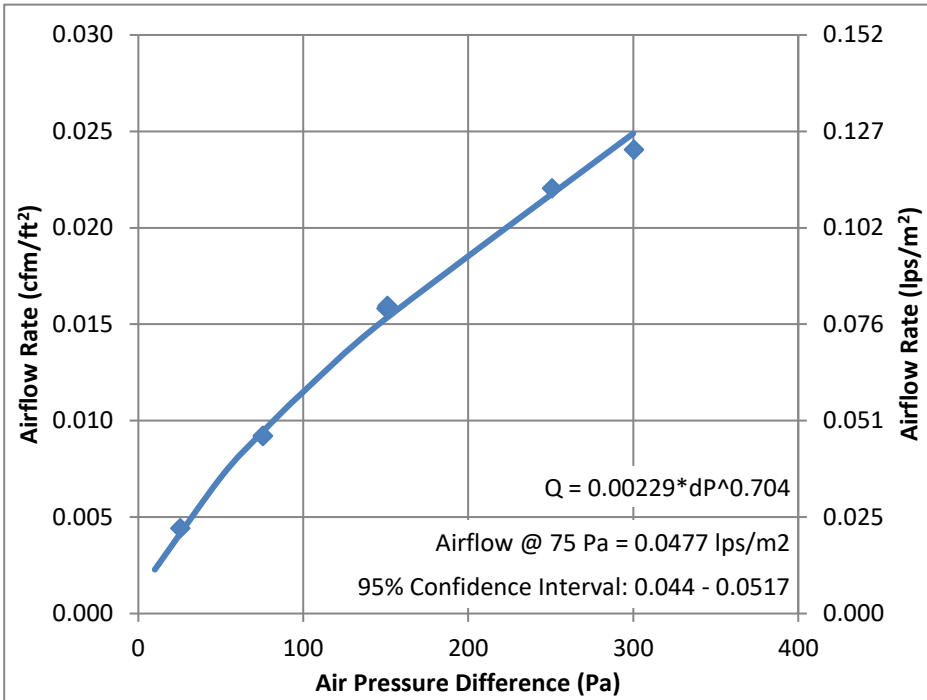

**Wall 1 – Single Wythe Precast – Opaque Wall
Post A (Sustained Pressure) Infiltration**

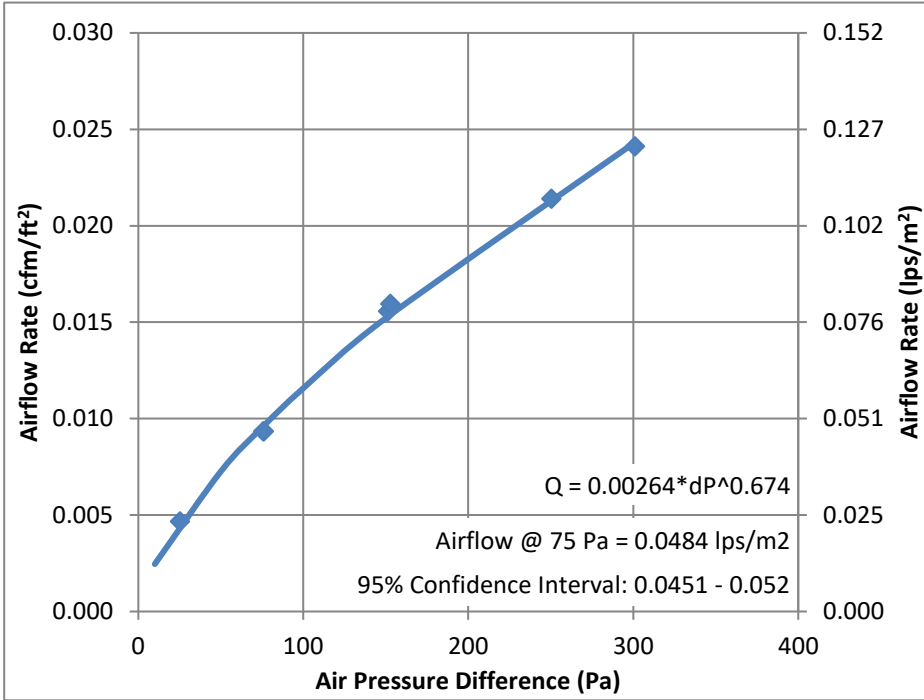

**Wall 1 – Single Wythe Precast – Opaque Wall
Post A (Sustained Pressure) Exfiltration**

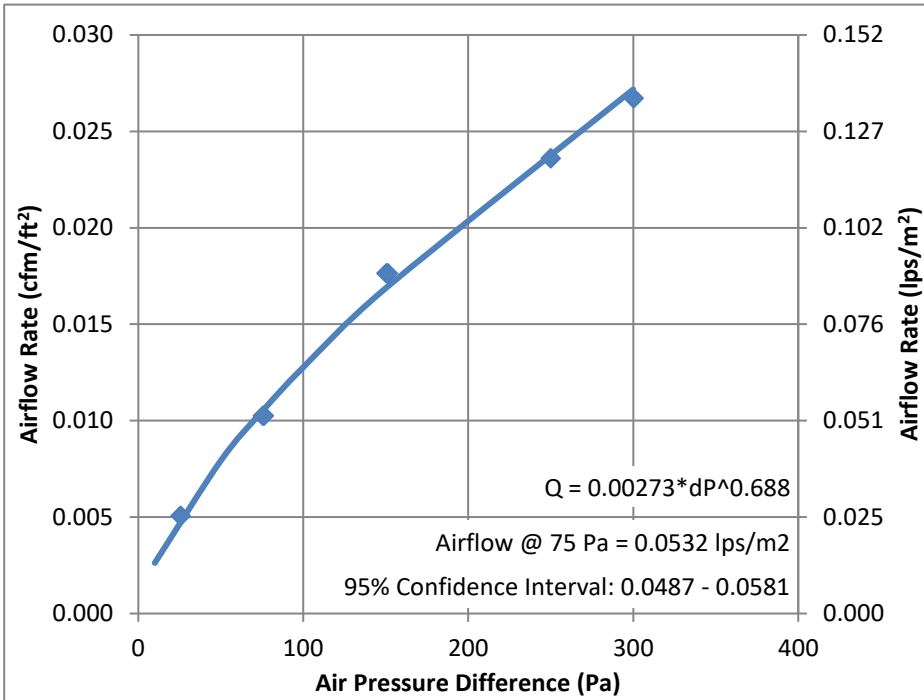

**Wall 1 - Single Wythe Precast - Opaque Wall
Post B (Cyclical Pressure) Infiltration**

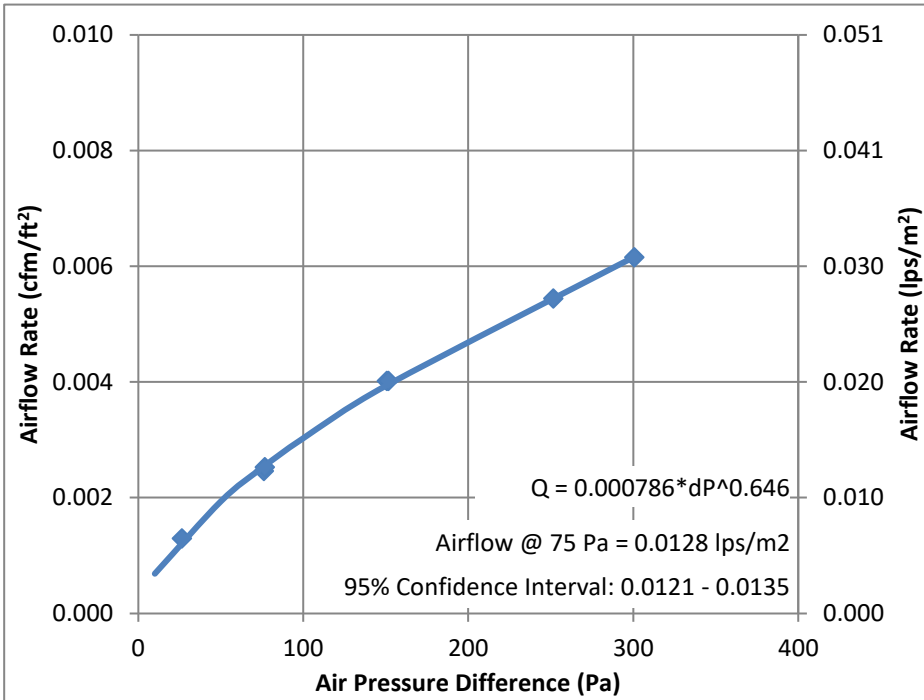

**Wall 1 - Single Wythe Precast - Opaque Wall
Post B (Cyclical Pressure) Exfiltration**

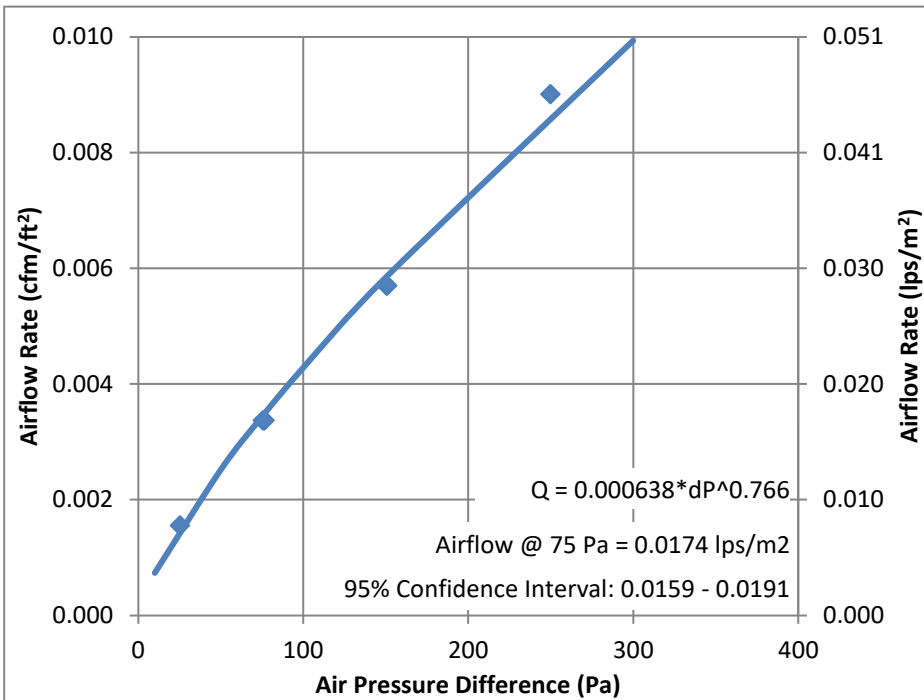

**Wall 1 – Single Wythe Precast – Opaque Wall
Post C (Gust Pressure) Infiltration**

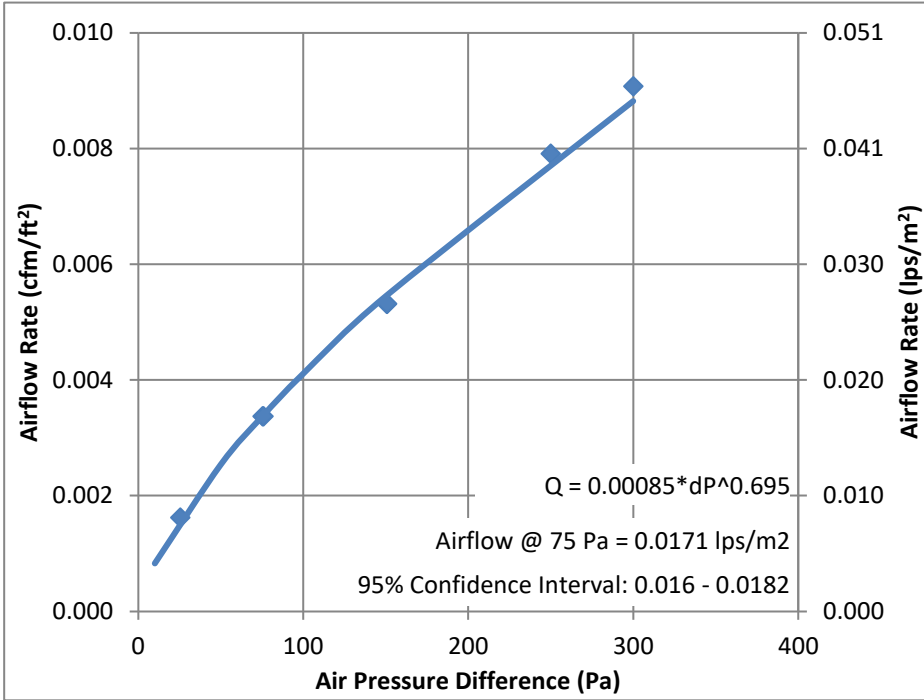

**Wall 1 – Single Wythe Precast – Opaque Wall
Post C (Gust Pressure) Exfiltration**

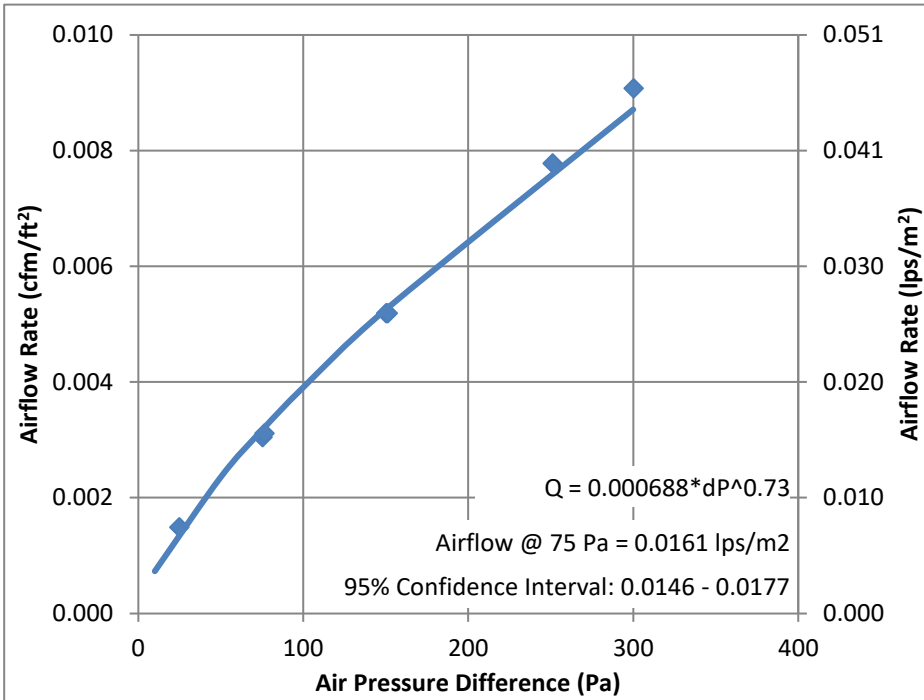

Wall 2 – Single Wythe Precast – Penetrated Wall Baseline Infiltration

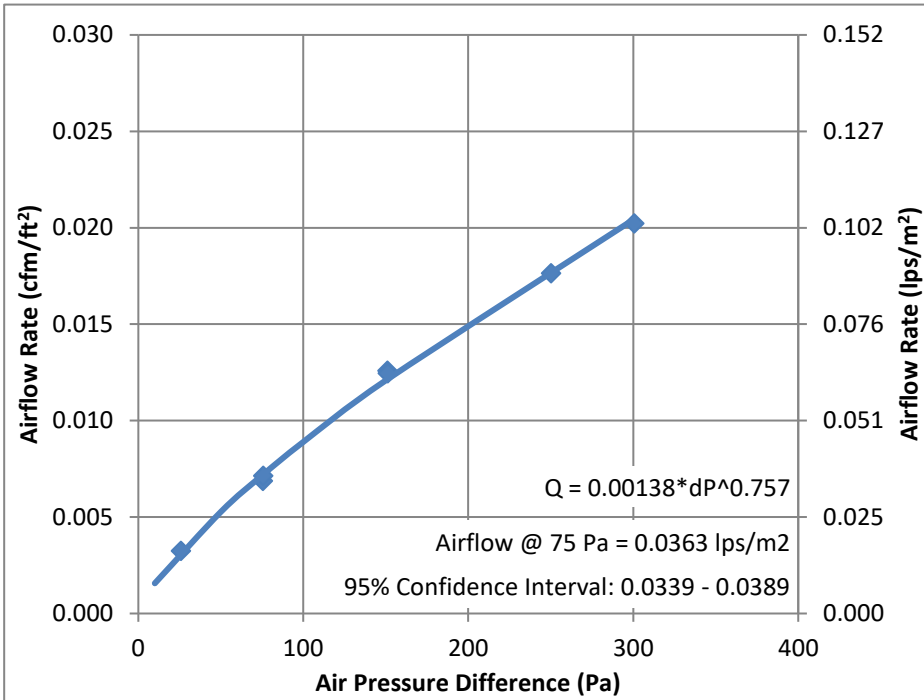

Wall 2 – Single Wythe Precast – Penetrated Wall Baseline Exfiltration

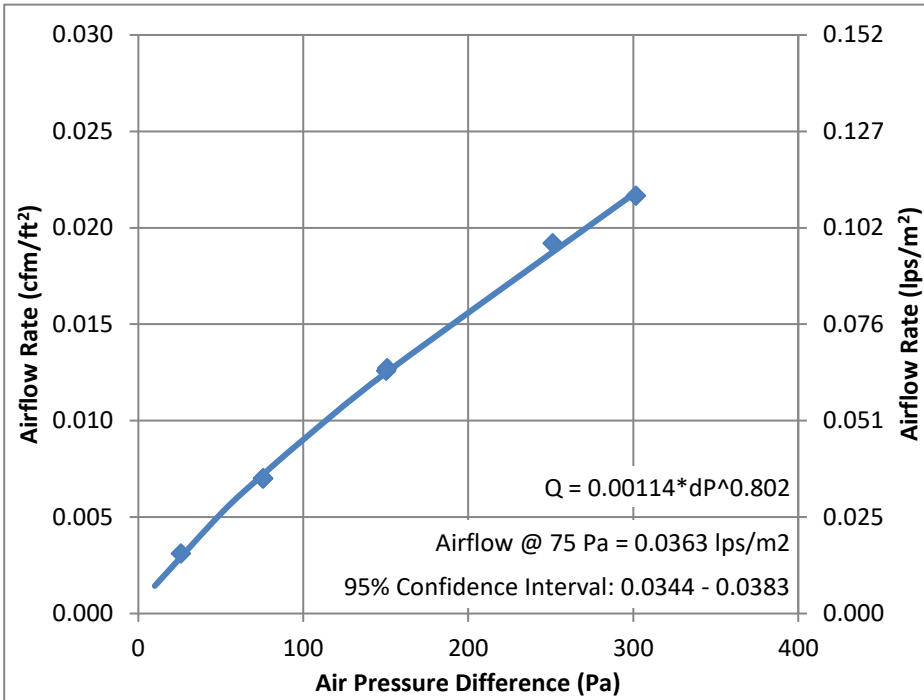

Wall 2 – Single Wythe Precast – Penetrated Wall Post A (Sustained Pressure) Infiltration

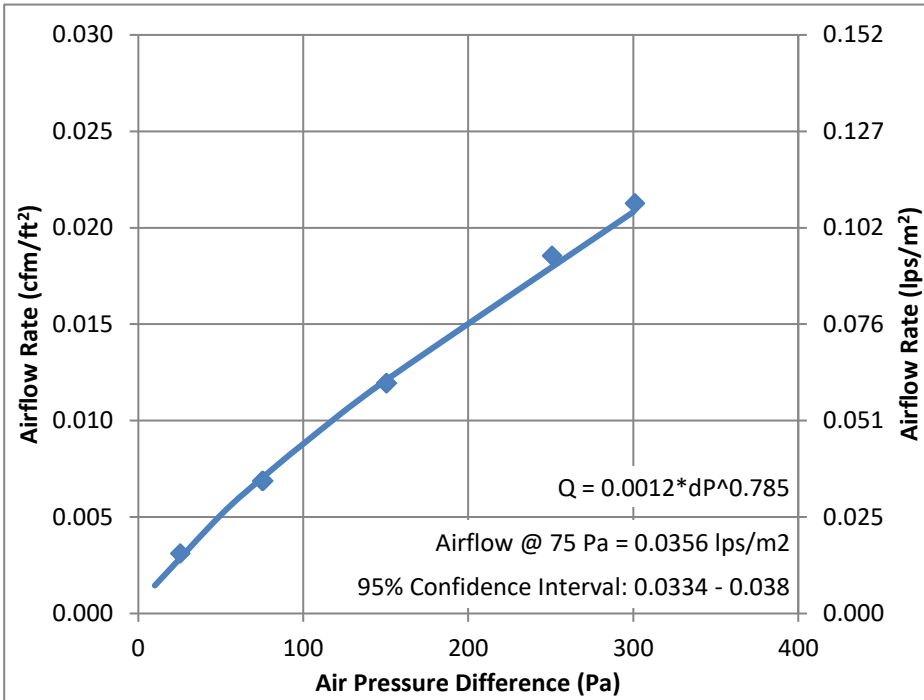

Wall 2 – Single Wythe Precast – Penetrated Wall Post A (Sustained Pressure) Exfiltration

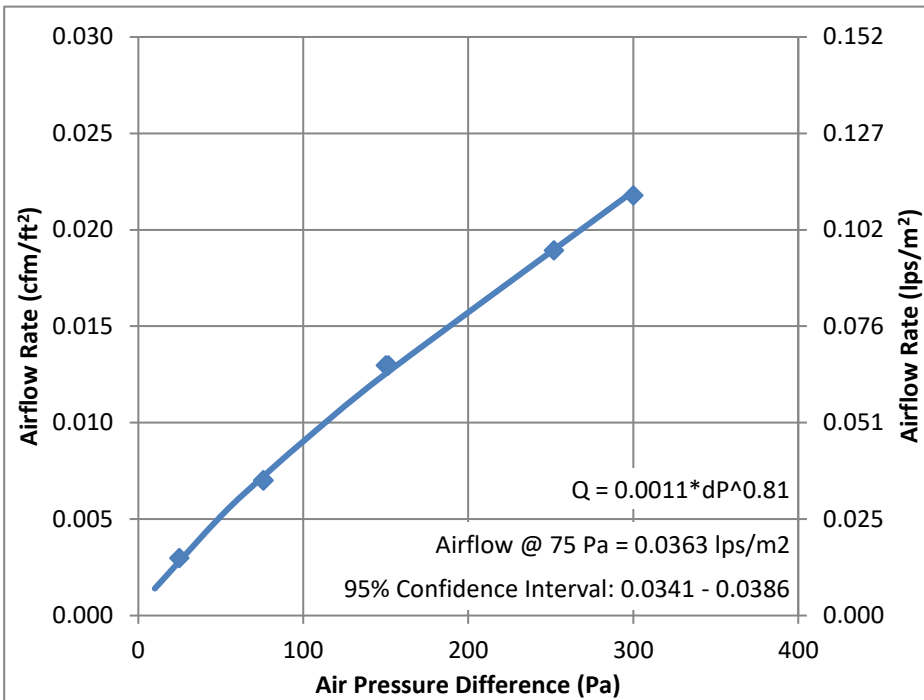

**Wall 2 – Single Wythe Precast – Penetrated Wall
Post B (Cyclical Pressure) Infiltration**

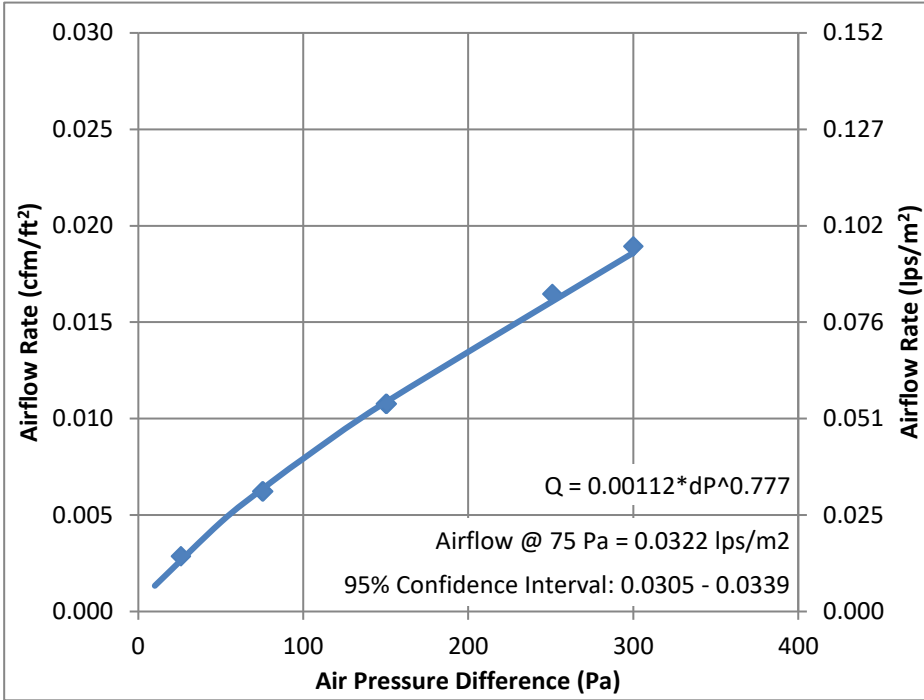

**Wall 2 – Single Wythe Precast – Penetrated Wall
Post B (Cyclical Pressure) Exfiltration**

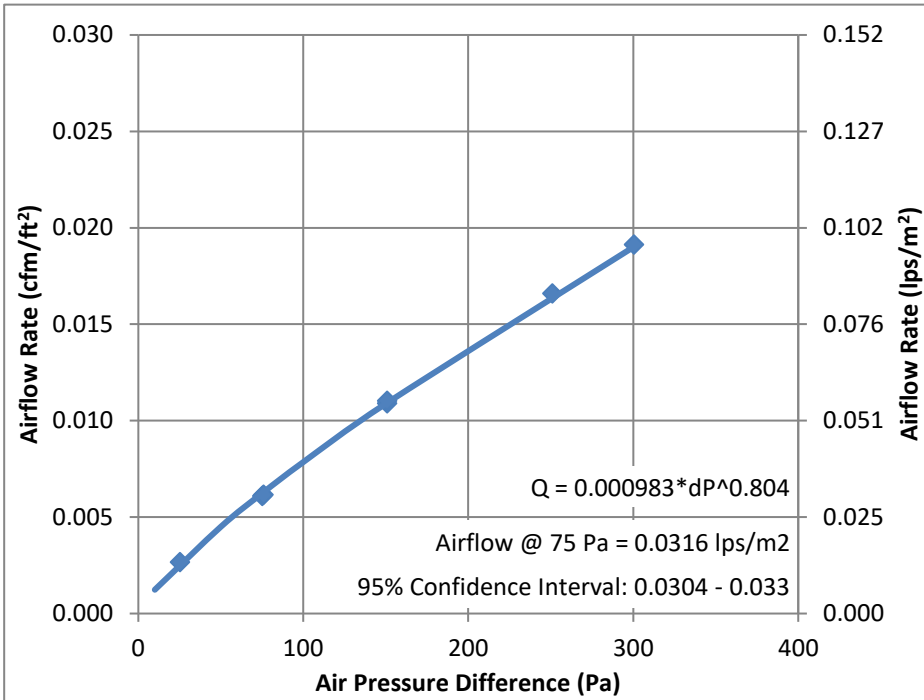

**Wall 2 – Single Wythe Precast – Penetrated Wall
Post C (Gust Pressure) Infiltration**

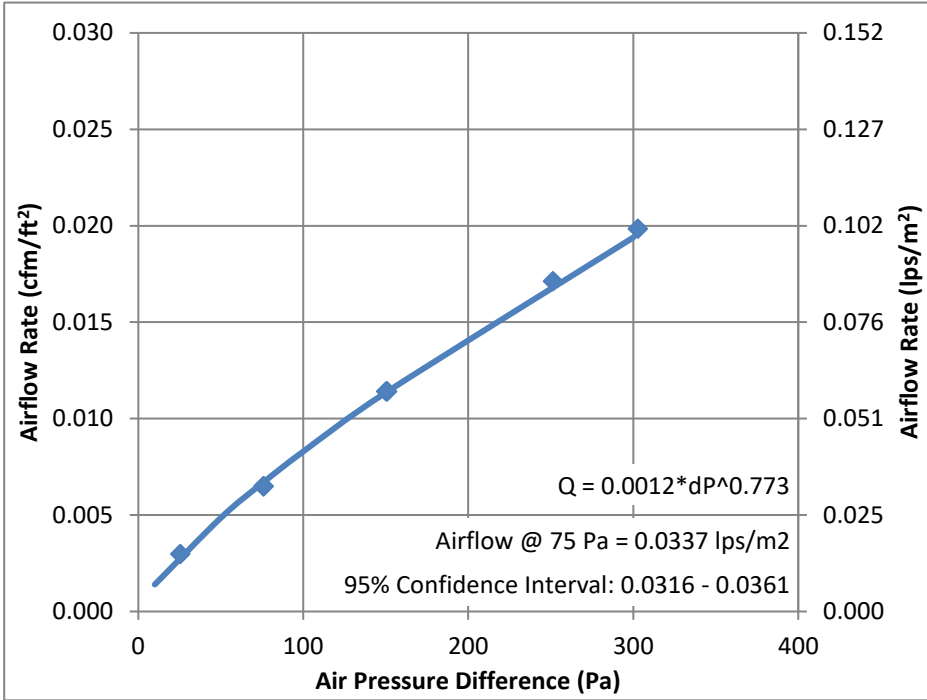

**Wall 2 – Single Wythe Precast – Penetrated Wall
Post C (Gust Pressure) Exfiltration**

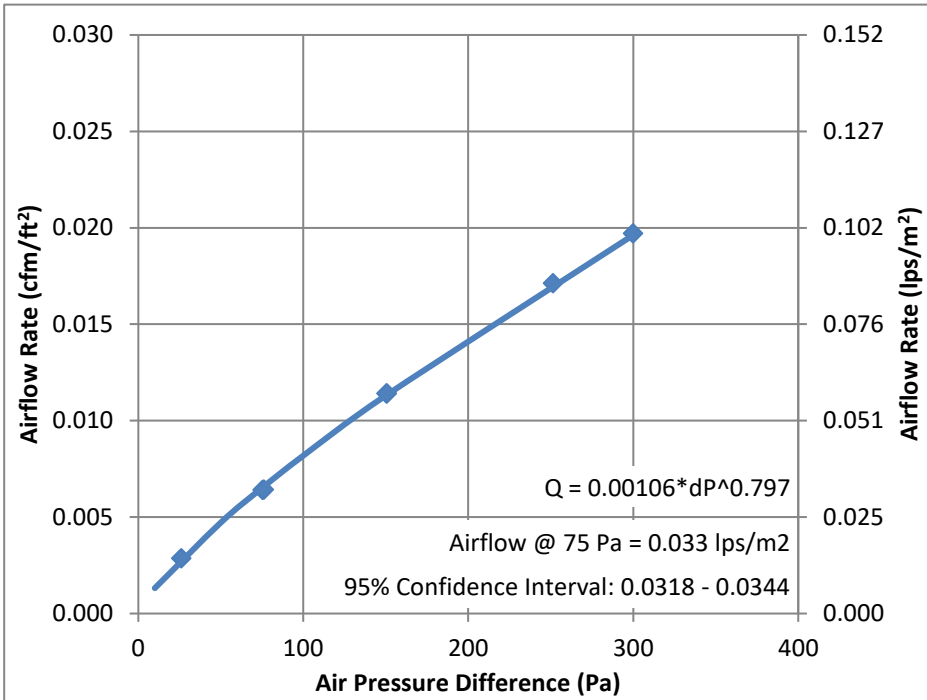

Wall 3 – Double Wythe Insulated Precast – Opaque Wall Baseline Infiltration

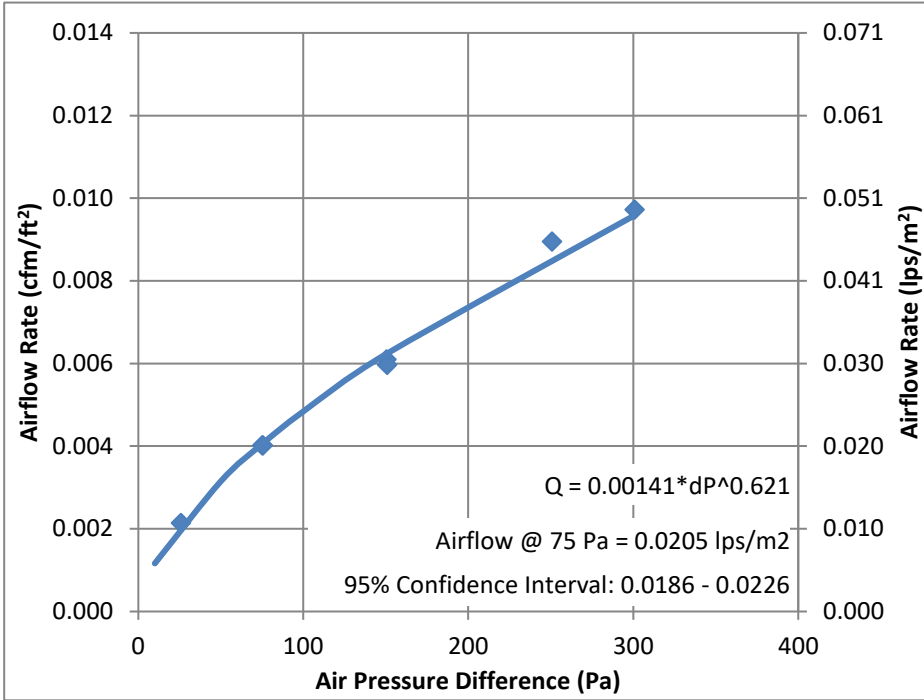

Wall 3 – Double Wythe Insulated Precast – Opaque Wall Baseline Exfiltration

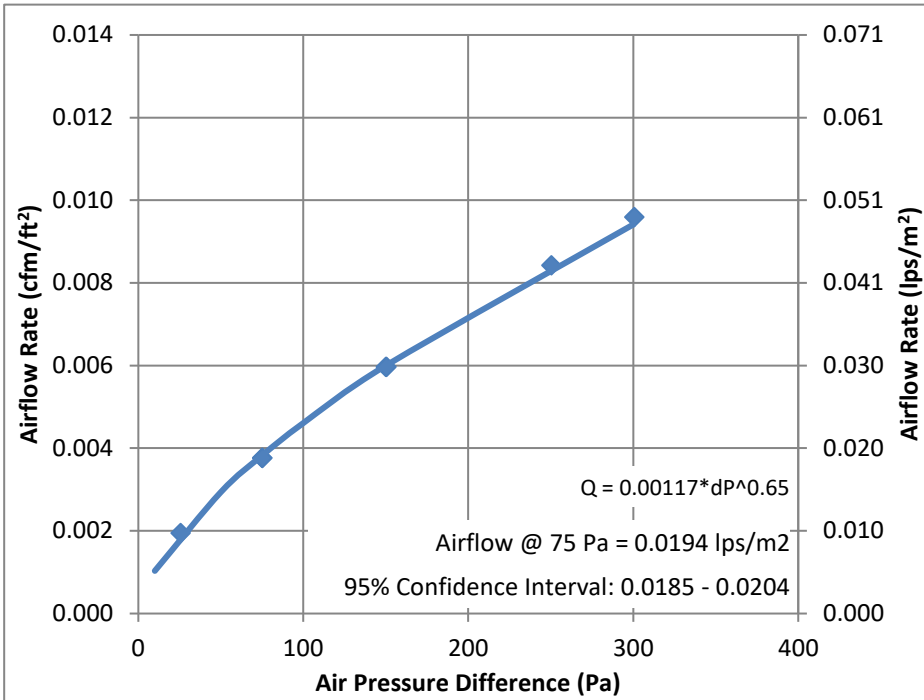

Wall 3 – Double Wythe Insulated Precast – Opaque Wall Post A (Sustained Pressure) Infiltration

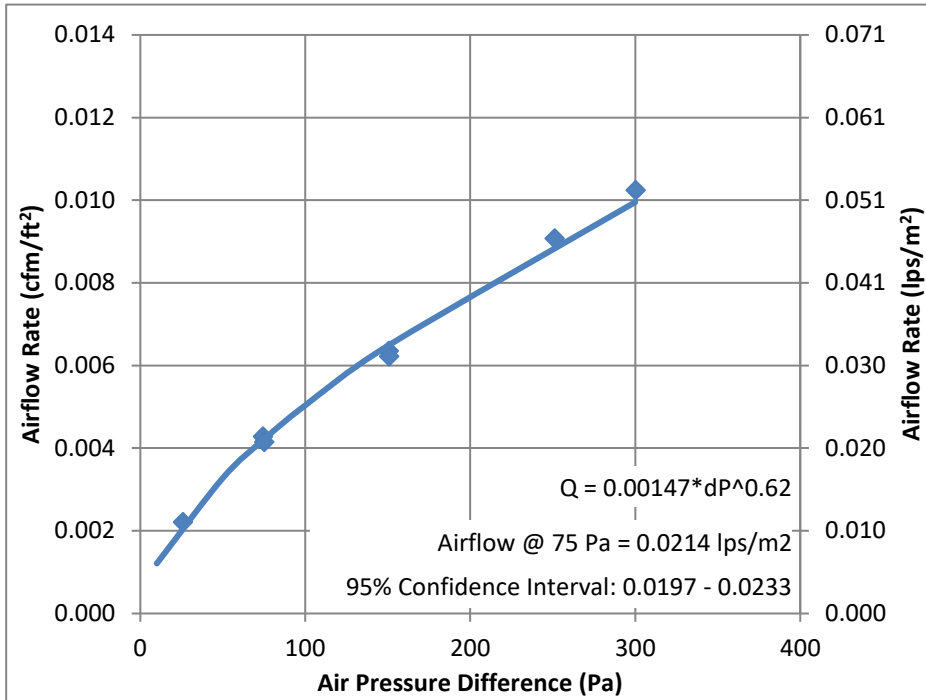

Wall 3 – Double Wythe Insulated Precast – Opaque Wall Post A (Sustained Pressure) Exfiltration

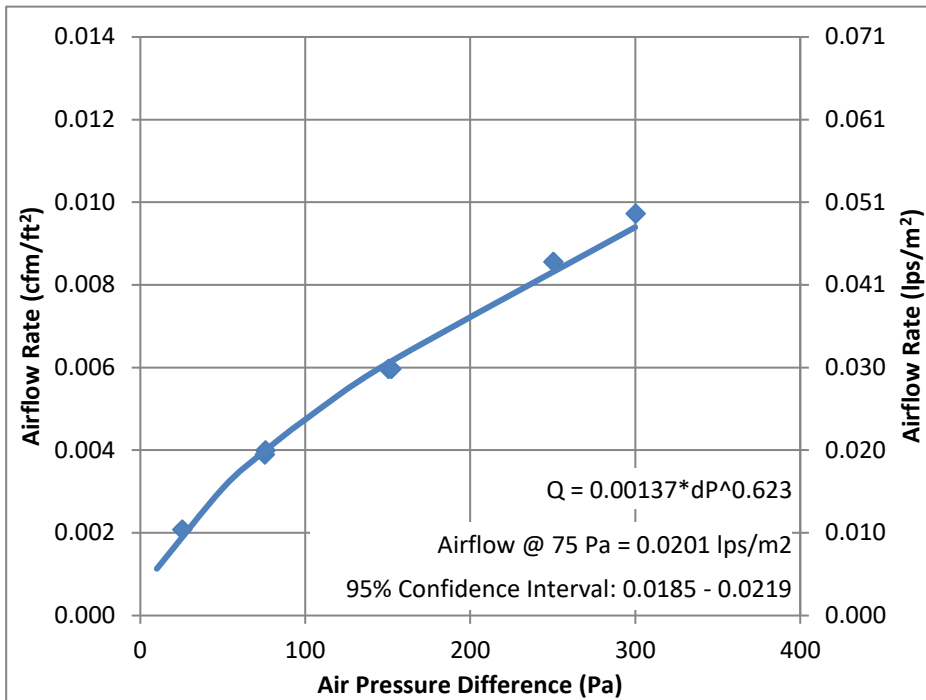

Wall 3 – Double Wythe Insulated Precast – Opaque Wall Post B (Cyclical Pressure) Infiltration

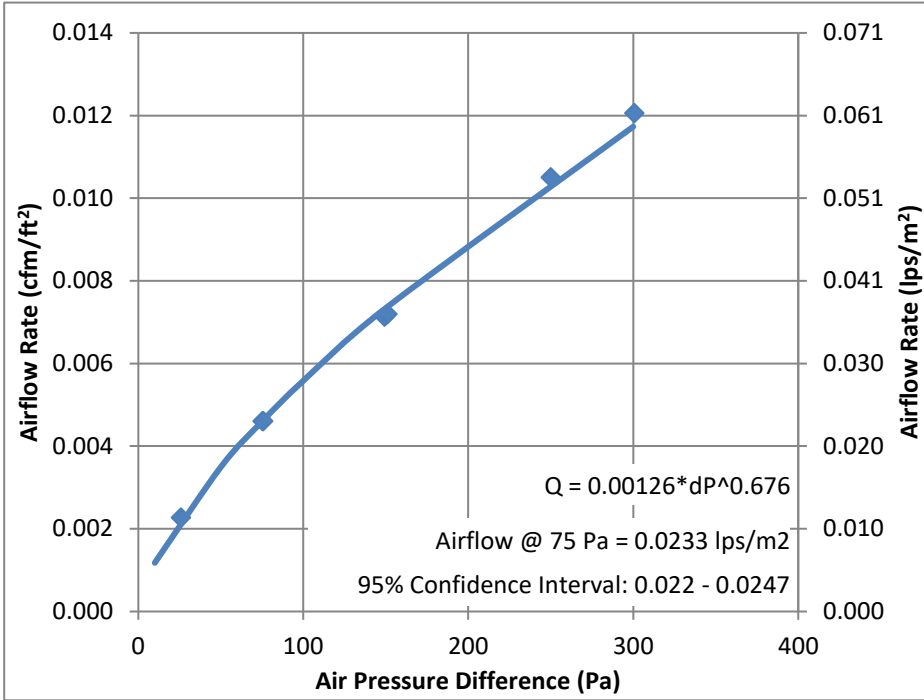

Wall 3 – Double Wythe Insulated Precast – Opaque Wall Post B (Cyclical Pressure) Exfiltration

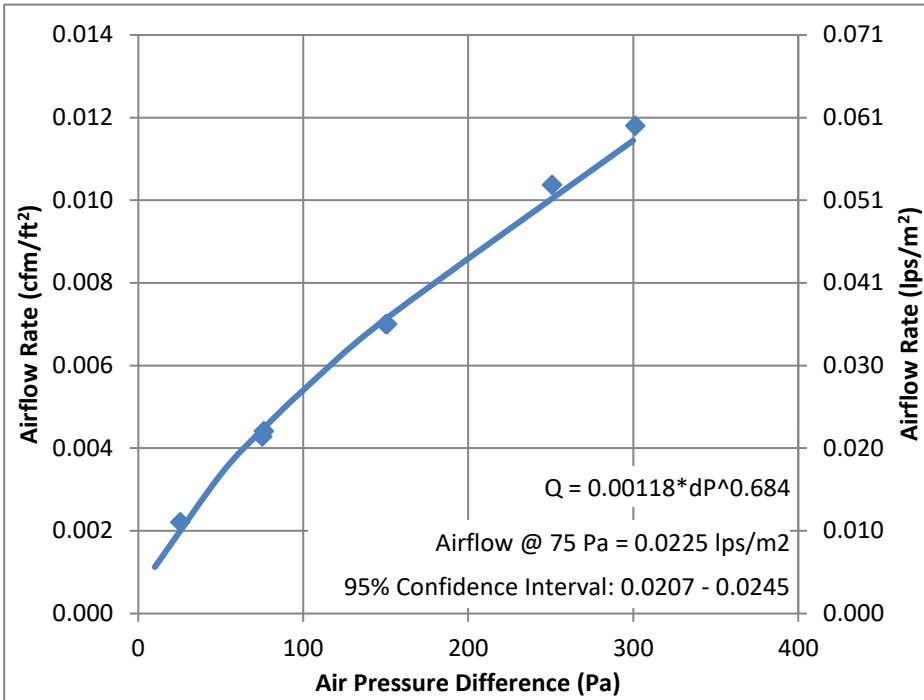

Wall 3 – Double Wythe Insulated Precast – Opaque Wall Post C (Gust Pressure) Infiltration

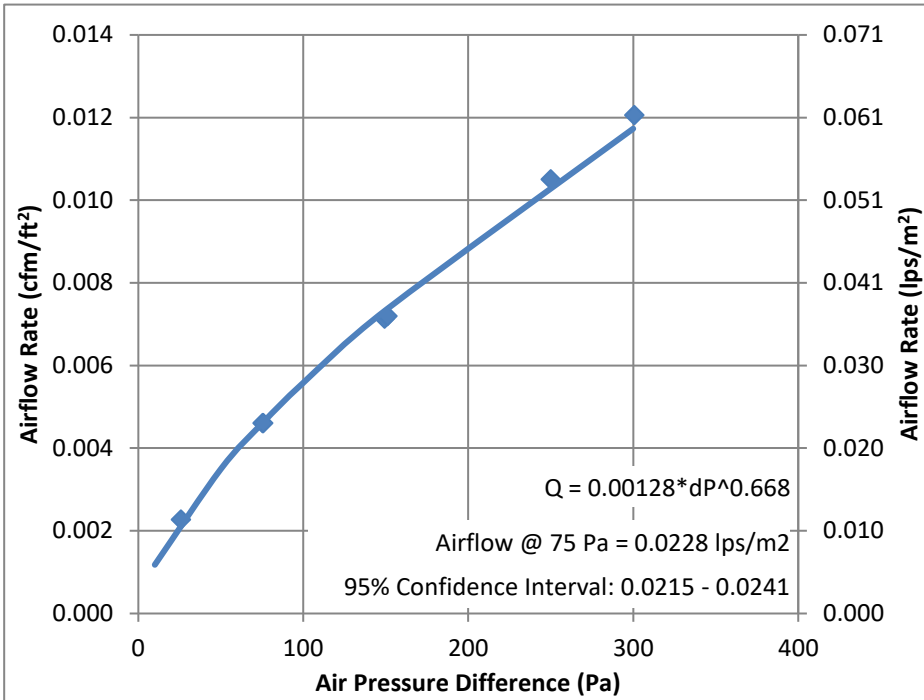

Wall 3 – Double Wythe Insulated Precast – Opaque Wall Post C (Gust Pressure) Exfiltration

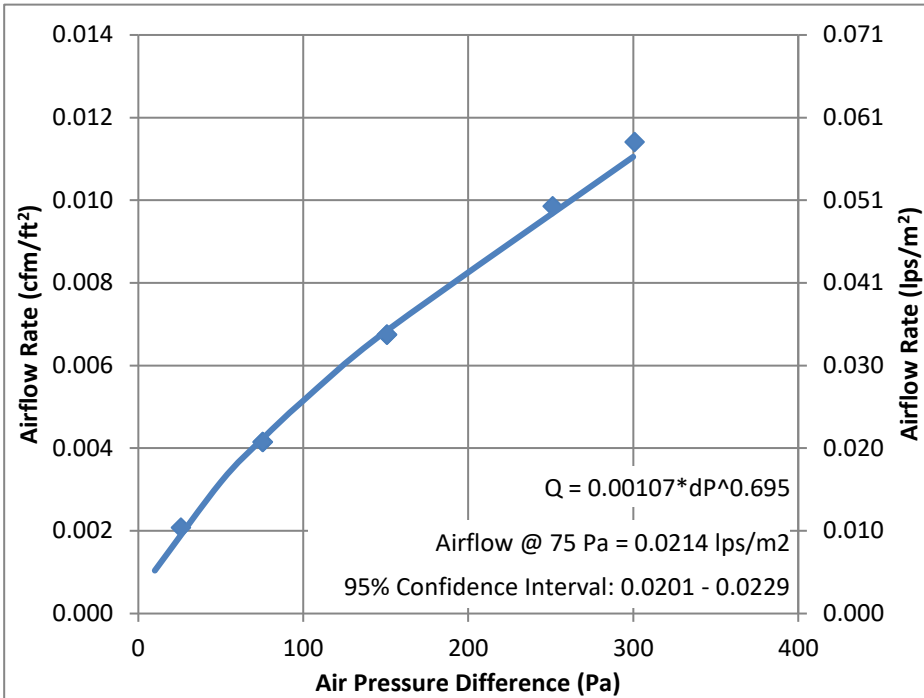

Wall 4 – Double Wythe Insulated Precast – Penetrated Wall Baseline Infiltration

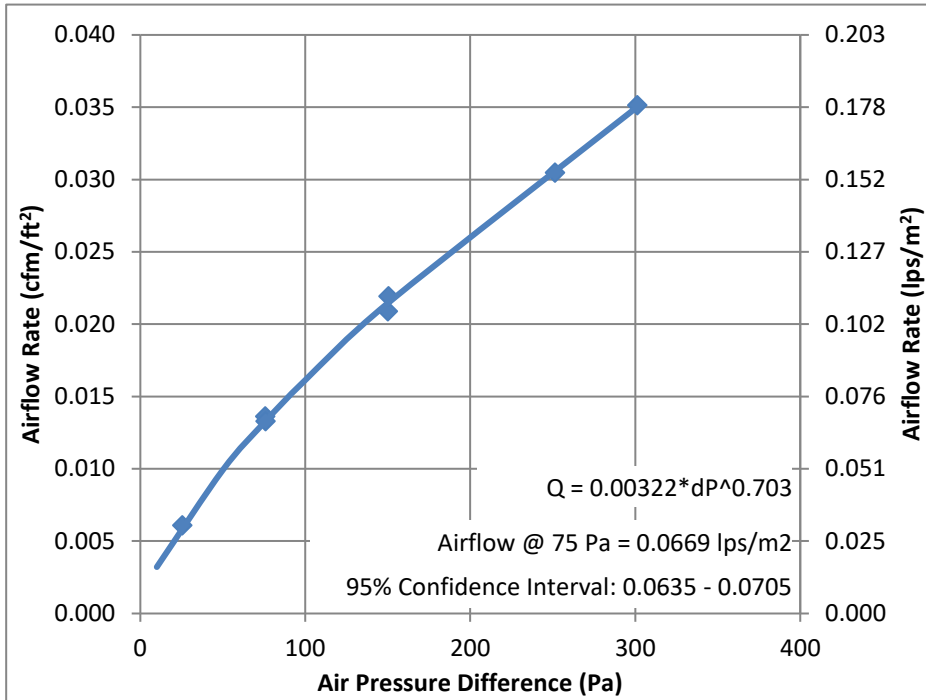

Wall 4 – Double Wythe Insulated Precast – Penetrated Wall Baseline Exfiltration

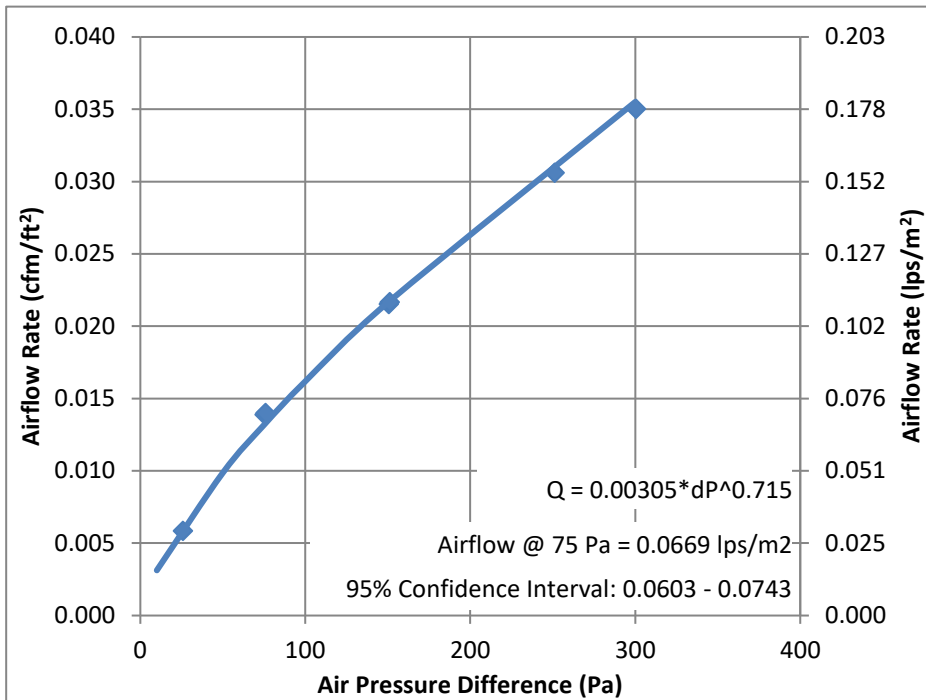

Wall 4 – Double Wythe Insulated Precast – Penetrated Wall Post A (Sustained Pressure) Infiltration

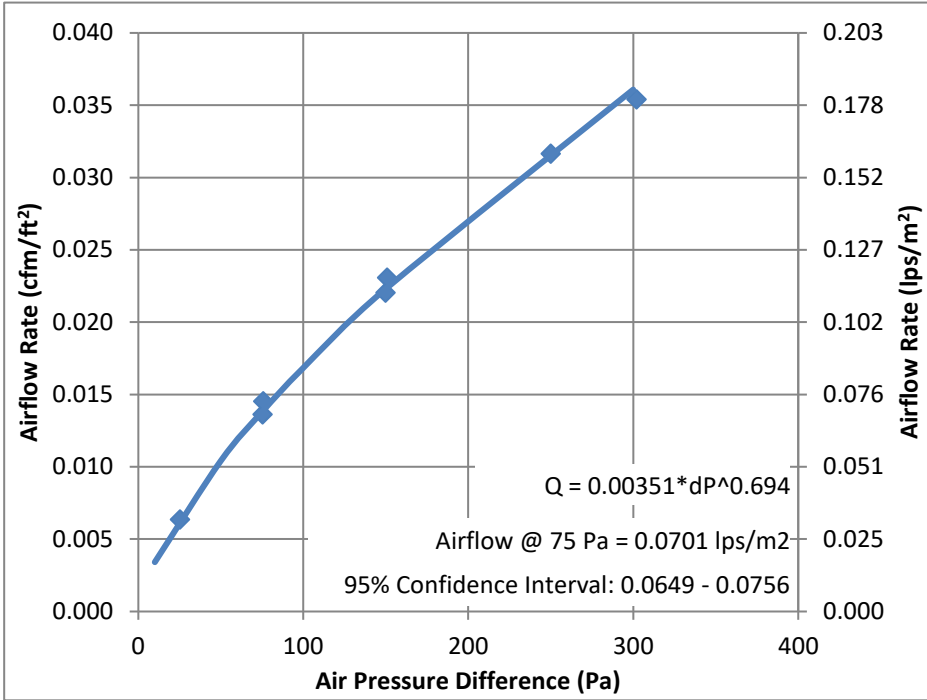

Wall 4 – Double Wythe Insulated Precast – Penetrated Wall Post A (Sustained Pressure) Exfiltration

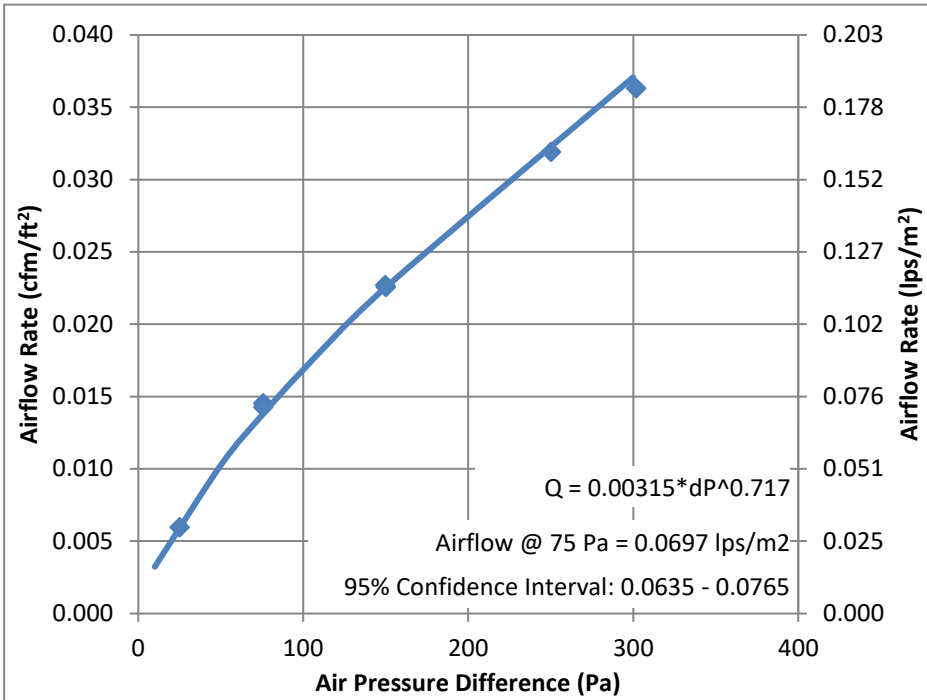

Wall 4 – Double Wythe Insulated Precast – Penetrated Wall Post B (Cyclical Pressure) Infiltration

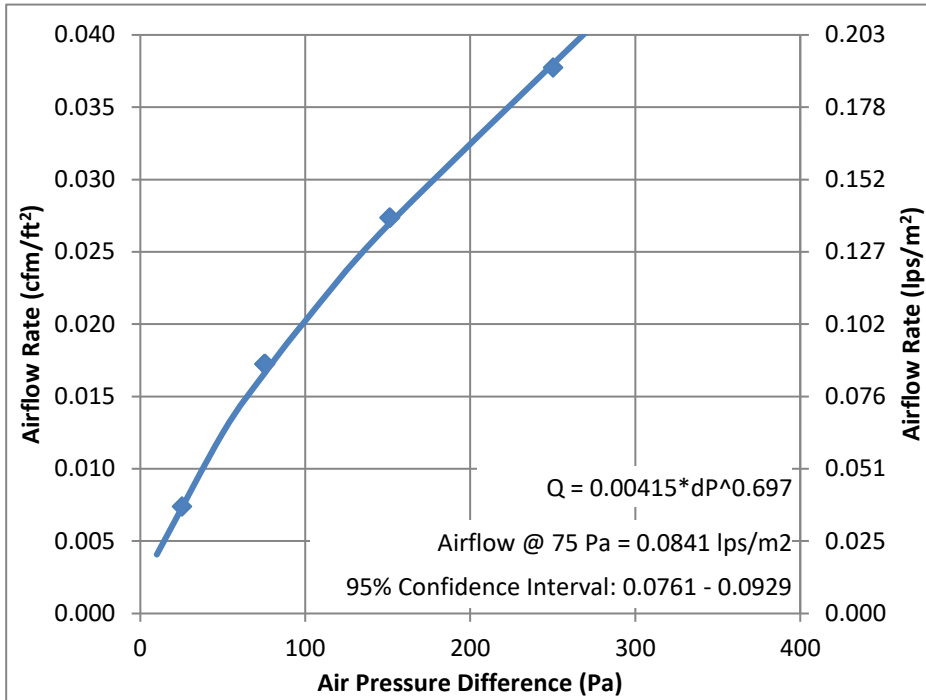

Wall 4 – Double Wythe Insulated Precast – Penetrated Wall Post B (Cyclical Pressure) Exfiltration

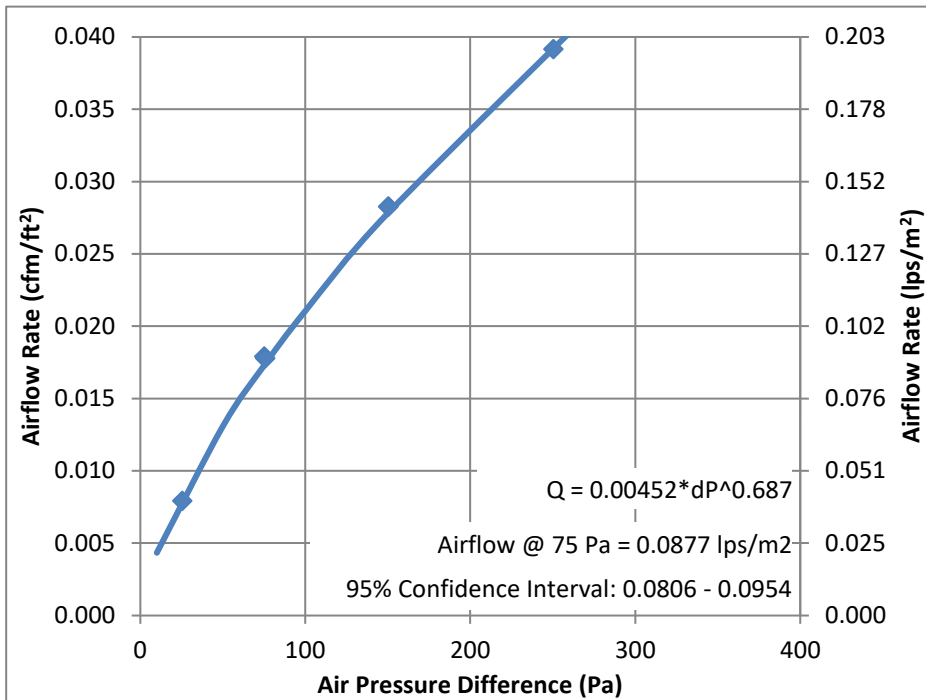

Wall 4 – Double Wythe Insulated Precast – Penetrated Wall Post C (Gust Pressure) Infiltration

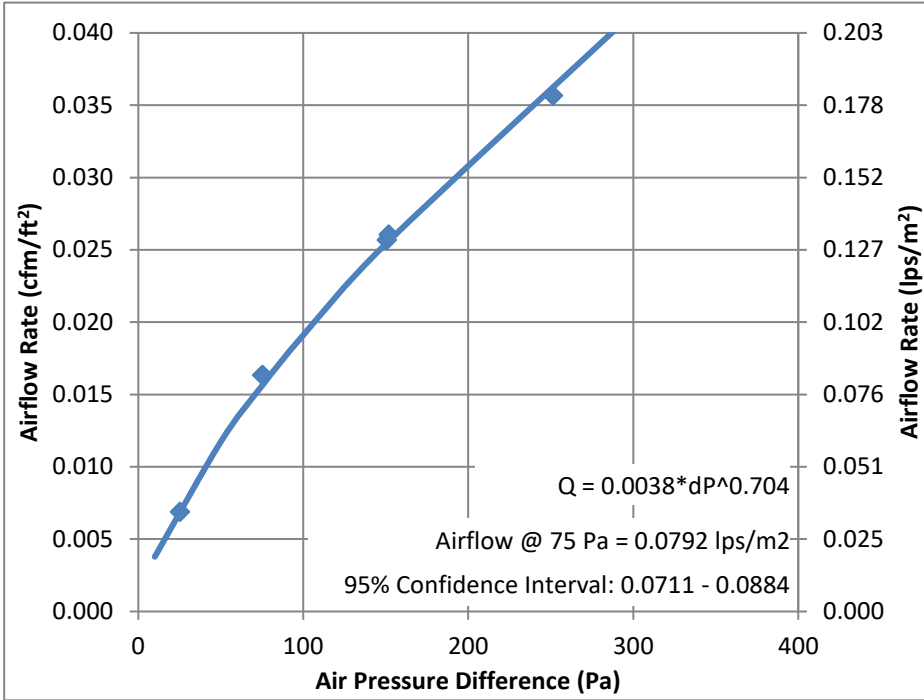

Wall 4 – Double Wythe Insulated Precast – Penetrated Wall Post C (Gust Pressure) Exfiltration

